

PFM Step-up 2-cell Lithium Battery Charger IC CN3312A/B/C

General Description:

CN3312A/B/C are PFM mode step-up battery charge management ICs with operating voltage range between 4.5V to 6.5V. It is specially designed for 2-cell lithium battery charge management with fewer external components. CN3312A/B/C adopts constant current and quasi-constant voltage(Quasi-CV™) mode to charge battery.

On power up, CN3312A/B/C enters charging state, the external N-channel MOSFET is turned on, inductor current rises. When inductor current reaches upper threshold, the N-channel MOSFET is turned off, the energy stored in inductor is transferred to battery. When the inductor current is discharged to its lower threshold, the N-channel MOSFET is turned on again. When BAT pin voltage reaches 8.4V(Typ.) for the first time, CN3312A/B/C enters quasi-CV mode, in which the charge current is reduced. The charge process will not be terminated until BAT voltage reaches 8.4V for the second time. In termination mode, the N-channel MOSFET is turned off. When BAT voltage falls below recharge threshold, the CN3312A/B/C enters charge mode again. CN3312A/B/C's switching frequency can be up to 1MHz, which makes a small-profile inductor usable.

The other features include chip enable input, chip over temperature protection, JEITA-compliant battery temperature monitoring, low battery protection and charge status indication, etc. CN3312A/B/C is available in thermally-enhanced 8-pin SOP package(eSOP8).

Applications:

- 2-cell Li+ Battery Charging Management
- Power Bank, POS, Electric Fan
- Audio System
- Standalone Charger

Features:

- Input Voltage Range: 4.5V to 6.5V
- Operating Current: 280uA@VIN=5V
- Can be Powered by Solar-panel
- No Need for External Current Sense Resistor
- Fixed Inductor Current:
CN3312A/B/CA: 2.65A
CN3312A/B/CB: 2A
CN3312A/B/CC: 1A
- Switching Frequency up to 1MHz
- Quasi-CV mode to Compensate for the Voltage Loss on Battery Internal Resistance and Trace Resistance
- Automatic Recharge
- JEITA-Compliant Battery Temperature Monitoring
- Low Battery and Short Battery Protection
- Automatic Adaptability to Input Supply with Limited Driving Capability
- Chip Enable Input
- Chip Over Temperature Protection
- Battery Overvoltage Protection
- Charge Status Indication
- Operating Temperature : -40°C to 85°C
- Available in Thermally-Enhanced SOP8 Package
- Lead-free, rohs-Compliant and Halogen Free

Pin Assignment

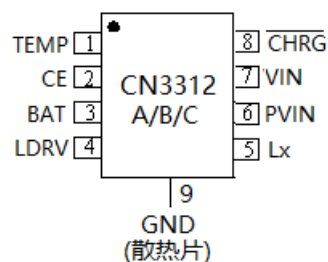

Note: Quasi-CV is the trade mark of Consonance Electronics

CONSONANCE

Typical Application Circuit:

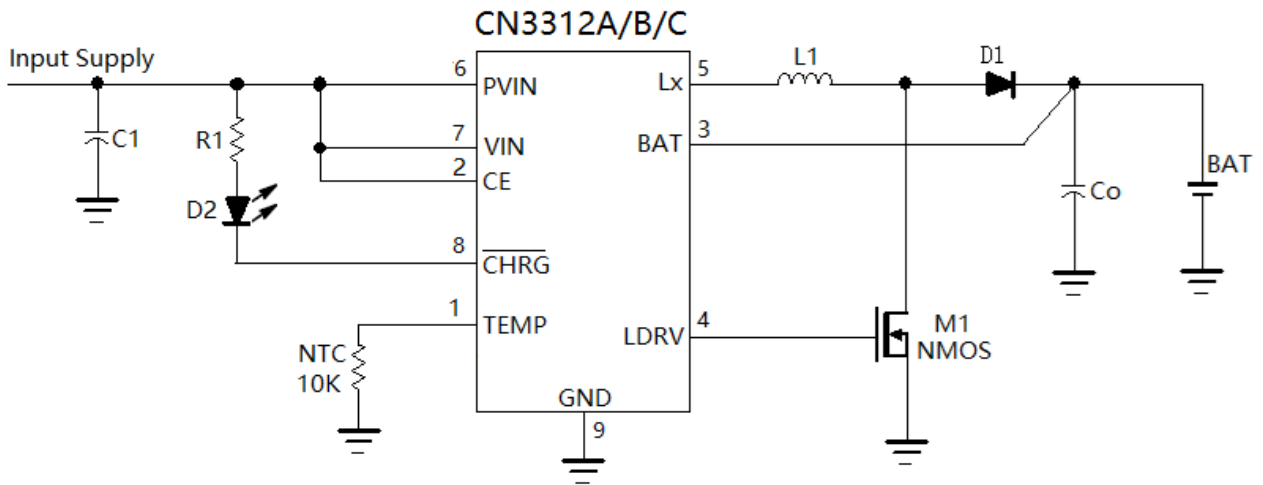

Figure 1 Typical Application Circuit (Fixed Input Current)

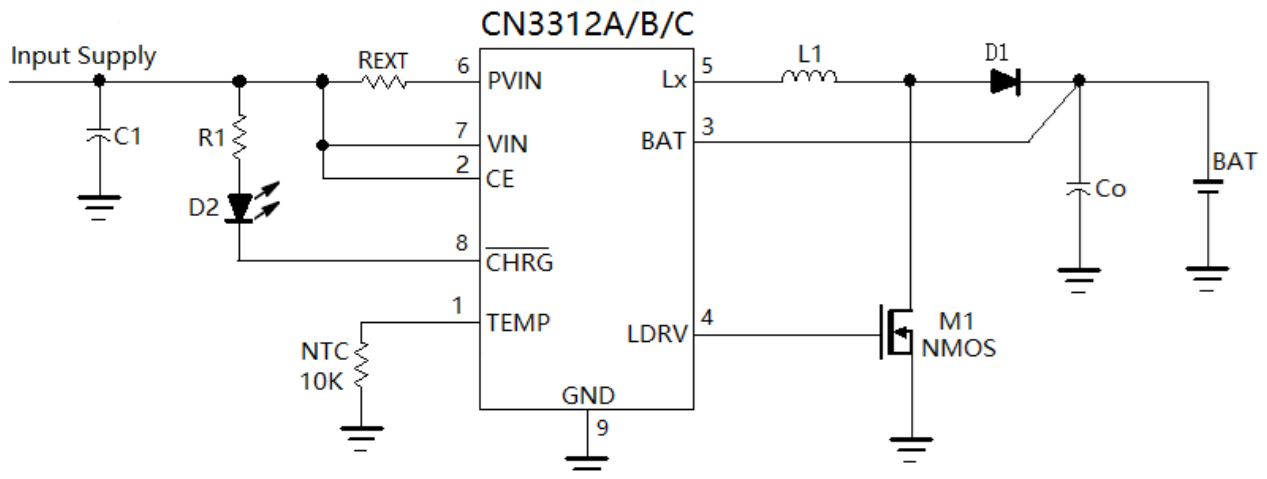

Figure 2 Typical Application Circuit (Reduce Input Current with R_{EXT})

CONSONANCE

Ordering Information:

Part No.	Package	Input Current	Top Marking	Shipping	Operating Temp
CN3312A	eSOP-8	2.65A	CN3312A	Tape&Reel, 4K/Reel	-40°C to 85°C
CN3312B	eSOP-8	2A	CN3312B	Tape&Reel, 4K/Reel	-40°C to 85°C
CN3312C	eSOP-8	1A	CN3312C	Tape&Reel, 4K/Reel	-40°C to 85°C

Block Diagram:

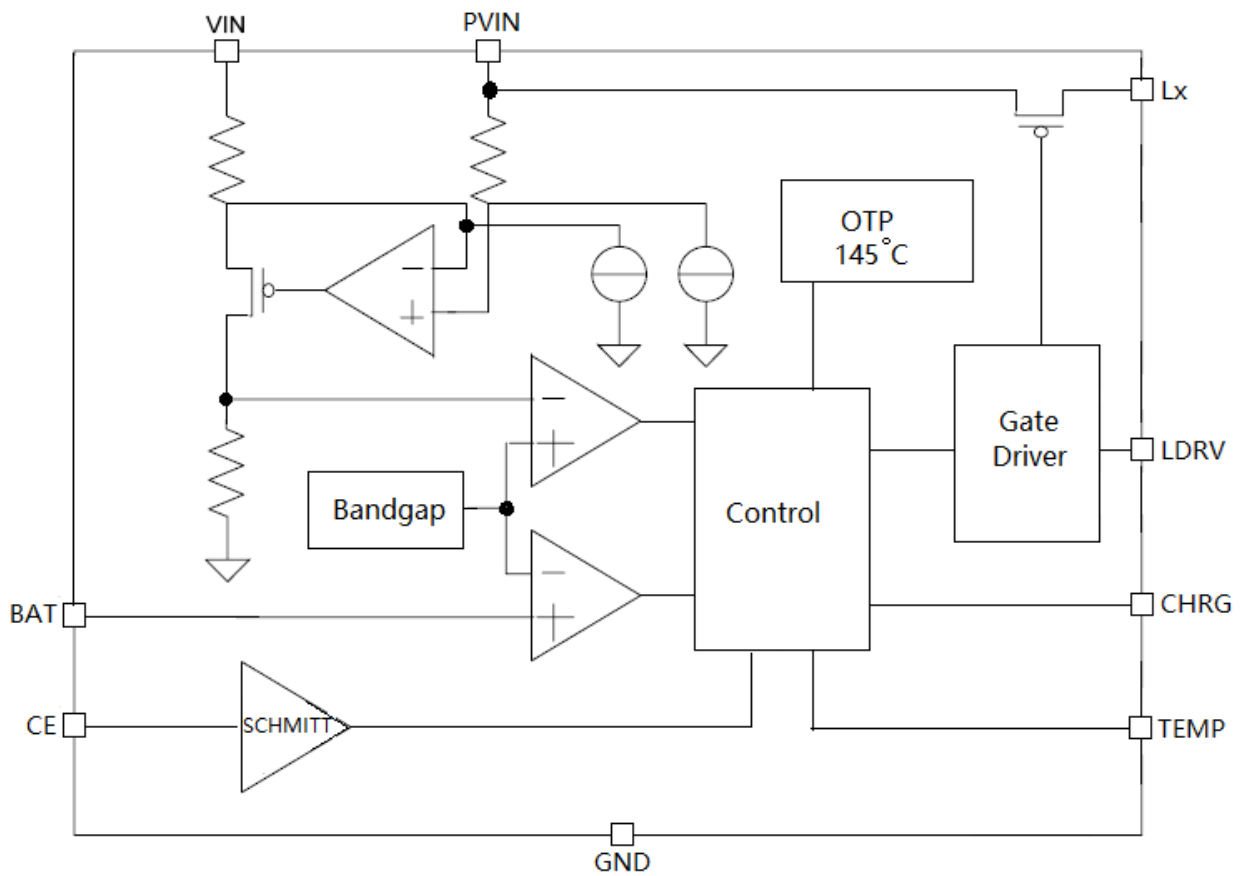

Figure 3 Block Diagram

CONSONANCE

Pin Description:

No.	Symbol	Description
1	TEMP	<p>Battery Temperature Monitoring Input. Connecting a 10K ohm NTC thermistor between TEMP pin and GND.</p> <ul style="list-style-type: none"> ● If TEMP pin's voltage is below 0.1V or above 0.85V, which means battery is too hot or too cold, charging is suspended. ● If TEMP's voltage is between 0.1V and 0.135V, which means battery is warm, charge current is reduced to 50% of full-scale current and termination voltage is reduced to $97.25\% * V_{term}$ ● If TEMP's voltage is between 0.135V and 0.55V, CN3312A/B/C functions normally. ● If TEMP's voltage is between 0.55V and 0.85V, which means battery is cool, charge current is reduced to 25% of constant current. <p>If battery temperature monitoring function is not needed, connect a fixed 10K ohm resistor from TEMP pin to GND.</p>
2	CE	<p>Chip Enable Input. A high input will put the device in the normal operating mode. Pulling the CE pin to low level will put the CN3312A/B/C into disable mode. The CE pin can be driven by TTL or CMOS logic level.</p>
3	BAT	<p>Battery Positive Terminal. BAT pin should be connected to battery's positive terminal to monitor battery voltage.</p>
4	LDRV	<p>Gate Drive for external N-Channel MOSFET. Connect LDRV pin to the gate of external N-Channel MOSFET.</p>
5	Lx	<p>Inductor Connection Terminal. Internally Lx pin is connected to drain of power P-channel MOSFET, and externally Lx pin is connected to one terminal of inductor. The inductor current flows out of Lx pin.</p>
6	PVIN	<p>Positive terminal of Power Input Supply. Internally PVIN is connected to power P-channel MOSFET, also a current sense resistor is at this pin, which set the input current(Inductor current) of CN3312A/B/C to 2.65A, 2A and 1A, respectively. The input current flows into CN3312A/B/C from PVIN pin. The input current(Inductor current) can be reduced if a current sense resistor is connected between VIN pin and PVIN pin.</p>
7	VIN	<p>Positive Terminal of Input Supply. CN3312A/B/C's internal circuit is powered by VIN pin,</p>
8	$\overline{\text{CHRG}}$	<p>Open Drain Charge Status Output. When the battery is being charged, the $\overline{\text{CHRG}}$ pin is pulled low by an internal switch, otherwise $\overline{\text{CHRG}}$ pin is in high impedance state.</p>
9	GND	<p>Exposed Thermal PAD. Internally the exposed PAD is electrically connected to CN3312A/B/C's ground (GND), which is the negative terminal of input supply and battery. Always solder the exposed PAD to the PCB and connected to system ground.</p>

CONSONANCE

ABSOLUTE MAXIMUM RATINGS

VIN and PVIN Voltage.....	-0.3V to 7.0V	Maximum Junction Temperature.....	150°C
BAT Voltage.....	-0.3V to 18V	Operating Temperature Range.....	-40°C to 85°C
TEMP, $\overline{\text{CHRG}}$, LDRV Voltage.....	-0.3V to 0.3V	Storage Temperature.....	-65°C to 150°C
Lx and CE Voltage.....	-0.3V to VIN	Lead Temperature(Soldering, 10s).....	260°C
CE and $\overline{\text{CHRG}}$ Current.....	15mA		

Stresses beyond those listed under “Absolute Maximum Ratings” may cause permanent damage to the device. These are stress ratings only, and functional operation of the device at these or any other conditions beyond those indicated in the operational sections of the specifications is not implied. Exposure to absolute maximum rating conditions for extended periods may affect device reliability.

ELECTRICAL CHARACTERICS:

(VIN = 5V, TA = -40°C to +85°C, Typical values are at TA = +25°C, unless otherwise noted)

Parameters	Symbol	Test Conditions	Min	Typ	Max	Unit	
Input Voltage Range	VIN		4.5		6.5	V	
Operating Current	IVIN	V _{BAT} =8.6V, No Switching	310	390	490	uA	
Turn-off Current	I _{off}	V _{CE} =0V		0	2	uA	
Switching Frequency	f _{SW}		200		1000	KHz	
Average Inductor Current (Average Input Current)	I _{CC}	Constant current mode	CN3312A	2.25	2.65	3.05	A
			CN3312B	1.7	2	2.3	
			CN3312C	0.85	1	1.15	
	I _{WARM}	Battery warm	CN3312A	1.12	1.33	1.53	
			CN3312B	0.85	1	1.15	
			CN3312C	0.42	0.5	0.58	
	I _{CV}	Quasi-CV Or Battery cool	CN3312A	0.56	0.66	0.76	
			CN3312B	0.42	0.5	0.58	
			CN3312C	0.21	0.25	0.29	
	I _{LOW1}	V _{BAT} =3V		88		mA	
I _{LOW2}	0.6V<V _{BAT} <2V		42				
I _{SRT}	V _{BAT} <0.6V		51				
PVIN Pin							
Internal Current Sense Resistor	R _{INT}	CN3312A	28	40	52	mohm	
		CN3312B	41	53	65		
		CN3312C	75	105	135		
BAT Pin							
Termination Voltage	V _{term}	BAT pin voltage rises	8.32	8.4	8.48	V	
Recharge Threshold	V _{rech}	BAT pin voltage falls	7.97	8.095	8.22	V	
BAT Pin Current	I _{BAT}	V _{BAT} =8.4V	3	5	7.5	uA	
Over-voltage Protection Threshold	V _{OV}	BAT pin voltage rises	1.044	1.0663	1.088	% V _{term}	
Over-voltage Release Threshold	V _{OVRLS}	BAT pin voltage falls	1.003	1.0249	1.047		

CONSONANCE

(Continued from Last Page)

Parameters	Symbol	Test Conditions	Min	Typ	Max	Unit
LDRV Pin						
LDRV Source Current		$V_{CSN}=V_{IN}, V_{DRV}=0.5 \times V_{CC}$		0.65		A
LDRV Sink Current		$V_{CSN}=V_{IN}-0.2V,$ $V_{LDRV}=0.5 \times V_{CC}$		0.65		A
Output High Level	V_{OH}	$I_{LDRV}=5mA$	$V_{CC}-0.3$			V
Output Low Level	V_{OL}	$I_{LDRV}=-5mA$			0.3	V
CE Pin						
CE Pin Input Low	V_{CEL}	CE voltage falls			0.7	V
CE Pin Input High	V_{CEH}	CE voltage rises	2.2			V
CE Pin Input Current	I_{CEL}	CE=GND, $V_{IN}=6V$			-1	uA
	I_{CEH}	CE= $V_{IN}=6V$			1	
TEMP Pin						
TEMP Pin Current	I_{TEMP}		27	30	33	uA
Cold Threshold	V_{COLD}	V_{TEMP} rises, cool to cold	800	850	900	mV
Cold Release Threshold	V_{COLDR}	V_{TEMP} falls, cold to cool	755	805	855	
Cool Threshold	V_{COOL}	V_{TEMP} rises, normal to cool	510	550	590	
Cool Release Threshold	V_{COOLR}	V_{TEMP} falls, cool to normal	465	505	545	
Warm Threshold	V_{WARM}	V_{TEMP} falls, normal to warm	120	135	150	
Warm Release Threshold	V_{WARMR}	V_{TEMP} rises, warm to normal	138	155	172	
Hot Threshold	V_{HOT}	V_{TEMP} falls, warm to hot	85	100	115	
Hot Release Threshold	V_{HOTR}	V_{TEMP} rises, hot to warm	105	120	135	
CHRG Pin						
\overline{CHRG} Sink Current	I_{SINK}	$V_{CHRG}=0.3V$, Charge mode	10			mA
\overline{CHRG} Leak Current	I_{LEAK}	$V_{CHRG}=6V$, Termination mode			1	uA
Chip Over-temperature Protection						
OTP Threshold	T_{OTP}	Chip temperature rises		145		°C
OTP Release Threshold	T_{RLS}	Chip temperature falls		127		°C

Detailed Description:

The CN3312A/B/C is a step up charge management IC for 2-cell lithium batteries with input voltage range from 4.5V to 6.5V.

The CN3312A/B/C is composed of reference voltage, inductor current sensing circuit, battery voltage detection circuit, battery over voltage protection circuit, low battery protection, logic control block, P-channel MOSFET and MOSFET driver, etc. The CN3312A/B/C is ideally suitable for 2-cell lithium batteries charging application with fewer external components.

CN3312A/B/C can also be powered by solar panel in addition to wall adaptors.

After power-on, CN3312A/B/C enters constant current charging mode, \overline{CHRG} pin outputs low to indicate that the charging is ongoing, the external N-channel MOSFET is turned on, the inductor current rises, and the energy stored in the output capacitor is transferred to battery. When the inductor current rises to the upper threshold, the N-channel MOSFET is turned off, the inductor current begins to fall, the energy stored in the inductor is transferred to the battery and the output capacitor. When the inductor current falls to the lower threshold, the

CONSONANCE

external N-channel MOSFET is turned on again, and so forth. The battery voltage is sensed by the on-chip resistor divider. When the battery voltage reaches 8.4V(Typical) for the first time, CN3312A/B/C enters quasi-CV mode after deglitching. In quasi-CV mode, the charge current is reduced to 25% of that in constant current mode. When the battery voltage reaches 8.4V(Typical) for the second time, the charging is terminated, the external N-channel MOSFET is turned off, CN3312A/B/C enters termination mode, and $\overline{\text{CHRG}}$ pin outputs high impedance to indicate the termination mode. In termination mode, there is no current flowing to the battery, when the battery voltage falls to 8.095V(Typical), CN3312A/B/C enters charge mode again. The highest switching frequency of CN3312A/B/C can be up to 1MHz, which makes the low-profile inductor usable.

CN3312A/B/C is a step-up charger IC, which means the battery voltage should be higher than the input voltage. In certain extreme cases, the battery voltage may be lower than the input voltage, or even the battery is shorted to GND, if these are the cases, CN3312A/B/C operates in linear mode to charge battery with a smaller current by controlling the on-chip P-channel MOSFET.

The other functions include chip enable input (CE pin), chip over temperature protection, JEITA-compliant battery temperature monitoring and battery over voltage protection, etc..

The charge profile is illustrated in Figure 4.

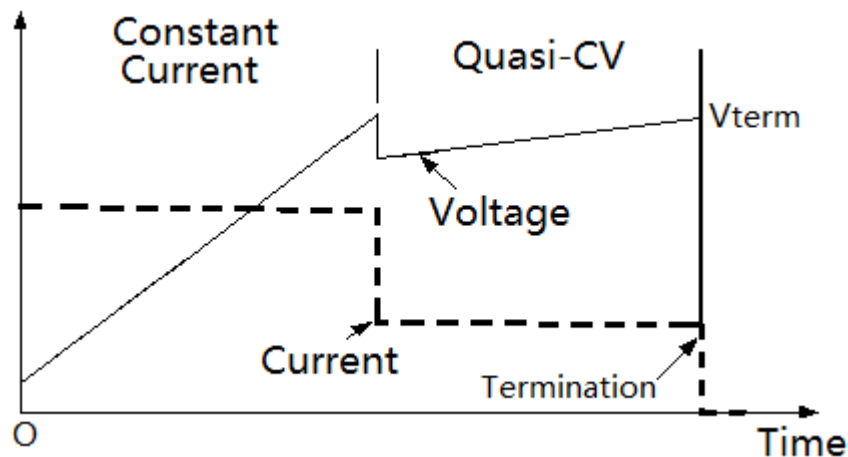

Figure 4 Charging Profile

Application Information:

Input Voltage Range

The CN3312A/B/C functions well when the input voltage is between 4.5V to 6.5V.

Chip Enable/Disable

There is a chip enable input CE pin. When the voltage at CE pin is above 2.2V, CN3312A/B/C functions normally; When the voltage at CE pin is below 0.7V, CN3312A/B/C is turned off. In turn-off state, the operating current is quite small (2uA Max.).

Do not apply a voltage between 0.7V and 2.2V on CE pin, otherwise CN3312A/B/C may be in uncertain state.

About Quasi-CV Mode

When the battery voltage is lower than 8.4V, CN3312A/B/C charges the battery with constant current. When battery voltage reaches 8.4V(Typical) for the first time, CN3312A/B/C enters quasi-CV mode, the charge current is reduced to 25% of that in constant current. When battery voltage reaches 8.4V(Typical) for the second time, CN3312A/B/C terminates the charging after deglitching. The quasi-CV mode can compensate for the voltage drop across the battery internal resistance to some extent, which is similar to constant voltage mode, this is why the quasi-CV mode is named.

CONSONANCE

Being powered by Solar Panel and Self-adaptive Function to Input Supply

CN3312A/B/C can adjust input current automatically to adapt the input supply's driving capability, which makes CN3312A/B/C ideal in applications of being powered by solar panel. This feature also makes it possible that the circuit design can be done based on the wall adaptor with strong driving capability for quick charge purpose, while the adaptor with weaker driving capability can also be used for charge purpose.

If input supply's driving capability is weak compared with the input current set by internal and external current sense resistor, CN3312A/B/C will regulate the input supply voltage to 4.4V (Typical) by reducing input current. To make sure CN3312A/B/C function correctly, the input supply like solar panel should be able to supply CN3312A/B/C's operating current, which is about several milliamperes depending on the external N-channel MOSFET used.

Inductor Current (Input Current)

An on-chip current sense resistor R_{INT} in CN3312A/B/C sets inductor current (Input current) at 2.65A, 2A and 1A, respectively when no external current sense resistor is used, namely VIN pin is shorted to PVIN pin.

If an external current sense resistor R_{EXT} is used together with R_{INT} , the inductor current (Input current) can be reduced. In this case, the total current sense resistor is $R_{CS}=R_{EXT}+R_{INT}$, where R_{INT} of CN3312A/B/C is 40m Ω , 53m Ω and 105m Ω , respectively. So the average inductor current, namely average input current, is:

$$\begin{aligned} I_L &= 0.105V / R_{CS} \quad (\text{Constant current mode}) \\ I_L &= 0.55V / R_{CS} \quad (\text{Battery warm}) \\ I_L &= 0.028V / R_{CS} \quad (\text{Quasi-CV mode or Battery cool}) \end{aligned}$$

Calculate Switching Frequency and Inductor

In the application circuit shown in Figure 1 and Figure 2, the on-time of external N-channel MOSFET is:

$$t_{on} = \frac{0.04 \times L}{V_{IN} \times R_{CS}} \quad \text{--- --- --- --- --- (1)}$$

The off-time of the N-channel MOSFET is:

$$t_{off} = \frac{0.04 \times L}{(V_{BAT} + V_D - V_{IN}) \times R_{CS}} \quad \text{--- --- --- --- --- (2)}$$

So the switching frequency is:

$$f_{sw} = \frac{1}{t_{on} + t_{off}} = \frac{1}{\frac{0.04 \times L}{V_{IN} \times R_{CS}} + \frac{0.04 \times L}{(V_{BAT} + V_D - V_{IN}) \times R_{CS}}}$$

CN3312A/B/C requires that the minimum switching frequency is no less than 200KHz. A frequency between 200KHz and 600KHz can achieve a good balance between efficiency and inductor size.

The switching frequency varies with input voltage and battery voltage, so when determining the switching frequency, the nominal battery voltage of 7.4V battery should be used.

Based on the requirements of input voltage range, charge current and switching frequency, the inductor value varies between 2.2uH and 15uH.

The duty cycle of CN3312A/B/C LDRV pin:

$$D = \frac{t_{on}}{t_{on} + t_{off}} = \frac{V_{BAT} + V_D - V_{IN}}{V_{BAT} + V_D}$$

In the above 2 equations:

L is the inductor value in Henry(H)

CONSONANCE

V_{IN} is the input voltage in Volt

V_{BAT} is battery voltage in Volt

V_D is the forward voltage drop of diode in Volt

R_{CS} is the total current sense resistance in ohm(Ω), R_{CS}=R_{EXT}+R_{INT}

If no external current sense resistor is used, namely VIN pin is connected to PVIN pin directly, then:

- For CN3312A, inductor value can be 3.3uH, Saturation current should be no less than 4A
- For CN3312B, inductor value can be 4.7uH, Saturation current should be no less than 3A
- For CN3312C, inductor value can be 10uH, Saturation current should be no less than 2A

Estimate Charge Current in Constant Current Mode

CN3312A/B/C controls charge current (CC) by monitoring inductor current, so the charge current in CC mode may vary with the input voltage and battery voltage.

Normally the following equation can be used to estimate the charge current:

$$I_{CH} = \frac{V_{IN} \times I_L \times \eta}{V_{BAT}}$$

Where,

I_{CH} is charge current in Ampere

V_{IN} is input voltage in Volts

I_L is the average inductor current in Ampere, and decided by 0.106 / R_{CS}

η is the conversion efficiency varying between 85% and 93%, generally 88% can be used.

V_{BAT} is battery voltage in Volt

Charge Termination

When BAT pin voltage reaches 8.4V(Typical) in Quasi-CV mode, the charging is terminated, the external N-channel MOSFET is turned off, no current flows to battery.

Recharge

In charge termination state, if voltage at BAT pin falls below 8.095V(Typical), CN3312A/B/C enters charge mode again.

Battery Temperature Monitoring

To prevent the damage caused by the very high or very low temperature done to the battery, the CN3312A/B/C continuously monitor battery temperature by measuring the voltage at TEMP pin which is determined by TEMP pin's source current (30uA typical) and a negative temperature coefficient(NTC) thermistor connected between TEMP pin and GND as shown in Figure 1 and Figure 2.

If battery temperature monitoring function is not needed, connect a fixed 10Kohm resistor from TEMP to GND.

The battery temperature monitoring function for CN3312A/B/C is designed to follow the JEITA standard; charge current or charge termination voltage is reduced based on battery temperature ranges.

There are totally five battery temperature ranges for CN3312A/B/C:

- Hot: Above 55°C,
- Warm: 45°C to 55°C,
- Normal: 10°C to 45°C
- Cool: 0°C to 10°C,
- Cold: Below 0°C.

Normal operation occurs when battery temperature is between 10°C and 45°C, charge current and voltage will be the normal values.

When battery is in the Cool temperature range, which is between 0°C and 10°C, the charge current is 25% of full-scale charge current and charge termination voltage is not changed.

When the battery is in the Warm temperature range, which is between 45°C and 55°C, the charge current is

CONSONANCE

reduced to 50% of full-scale charge current and charge termination voltage is reduced to 97.25% of 8.4V.

Charging is suspended if battery temperature is below Cold temp of 0°C or above Hot temp of 55°C. When charging is suspended, $\overline{\text{CHRG}}$ pin becomes high impedance state.

Once battery temperature is not in hot range and cold range, charging resumes automatically.

TEMP pin voltage is the product of its source current and NTC's resistance, so the selection of NTC should make sure TEMP pin voltage meet the requirements of hot, warm, cool and cold threshold. An NTC of nominal resistance 10K ohm at room temperature may be suitable for CN3312A/B/C.

A resistor of small resistance in series with NTC thermistor and a resistor of large resistance in parallel with NTC thermistor can fine tune CN3312A/B/C's temperature range.

The following table lists TEMP pin voltage, charge current and termination voltage in the above-mentioned 5 battery temperature range.

Battery Temperature Range	TEMP Pin Voltage	Charge Current	Regulation Voltage
Hot: above 55°C	$V_{\text{TEMP}} < V_{\text{HOT}}$	Charge Suspended	Charge Suspended
Warm: 45°C to 55°C	$V_{\text{HOTR}} < V_{\text{TEMP}} < V_{\text{WARM}}$	50% * I _{CC}	97.25% * V _{TERM}
Normal: 10°C to 45°C	$V_{\text{WARMR}} < V_{\text{TEMP}} < V_{\text{COOLR}}$	Normal Value	Normal Value
Cool: 0°C to 10°C	$V_{\text{COOL}} < V_{\text{TEMP}} < V_{\text{COLDR}}$	25% * I _{CC}	Normal Value
Cold: below 0°C	$V_{\text{TEMP}} > V_{\text{COLD}}$	Charge Suspended	Charge Suspended

Open-drain Charge Status Output

CN3312A/B/C has an open-drain charge status output $\overline{\text{CHRG}}$, which can be used to drive LED or interface with MCU, $\overline{\text{CHRG}}$ pin is pulled to low level in charge status; In termination status, or output over voltage state, or battery hot, or battery cold, $\overline{\text{CHRG}}$ pin outputs high impedance state.

If battery is absent, CN3312A/B/C charges output capacitor to over voltage protection level, then the output capacitor is discharged to over voltage release threshold, then CN3312A/B/C charges output capacitor to over voltage protection level again, and so forth. $\overline{\text{CHRG}}$ pin outputs a pulse to indicate the battery is absent.

Selection of N-Channel MOSFET

The CN3312A/B/C's gate driver is capable of sourcing 0.65A and sinking 0.65A of current. MOSFET selection is based on the maximum battery voltage, inductor current and operating switching frequency. Choose an N-channel MOSFET that has a higher breakdown voltage than the maximum battery voltage, low R_{ds(ON)}, and low total gate charge(Q_g) for better efficiency. MOSFET threshold voltage must be adequate if operated at the low end of the input-voltage operating range.

Selection of Free-Wheeling Diode

The forward voltage of the freewheeling diode (D1 in Fig.1 and Fig.2) should be as low as possible for better efficiency. A Schottky diode is a good choice as long as the breakdown voltage is high enough to withstand the maximum battery voltage. The current rating of the diode must be greater than the maximum charge current.

Input Capacitor

In most applications, a bypass capacitor at VIN is needed. An at least 4.7uF ceramic capacitor, placed in close proximity to VIN and GND pins, works well. In some applications depending on the power supply characteristics and cable length, it may be necessary to increase the capacitor's value. The capacitor's breakdown voltage should be higher than the maximum input voltage.

Generally a capacitor between 4.7uF and 47uF works well, ceramic capacitor of X5R or X7R is highly recommended.

Output Capacitor

A filter capacitor (C_o in Figure 1 and Figure 2) is needed between battery positive terminal and ground, the capacitor also supply energy to battery when the N-channel MOSFET is in on state.

The output capacitance is determined by the requirement of output ripple voltage. The ripple voltage is decided

CONSONANCE

by the following equation:

$$\Delta V_{BAT} = \frac{I_{CH} \cdot t_{off}}{C_o} + \frac{0.04 \cdot I_{esr}}{R_{cs}}$$

- Where, I_{CH} is the charge current flowing into battery
- t_{off} is the off time of N-channel MOSFET
- C_o is the output capacitance
- r_{esr} is the equivalent series resistance of output capacitor
- R_{cs} is the total current sense resistor, $R_{CS}=R_{EXT}+R_{INT}$

So the ESR of output capacitor should be as small as possible, X5R or X7R ceramic capacitors are recommended.

Chip Over-Temperature Protection

If CN3312A/B/C's silicon temperature rises above 145°C due to certain reasons, the over temperature protection mode is asserted, LDRV pin outputs low level which turns off the external N-channel MOSFET. In this case, CN3312A/B/C will not go back to normal operation until the silicon temperature falls below 127°C.

Adjust Charge Termination Voltage upwards

The charge termination voltage can be adjusted upwards by placing a resistor between battery's positive terminal and CN3312A/B/C's BAT pin as shown in Figure 5.

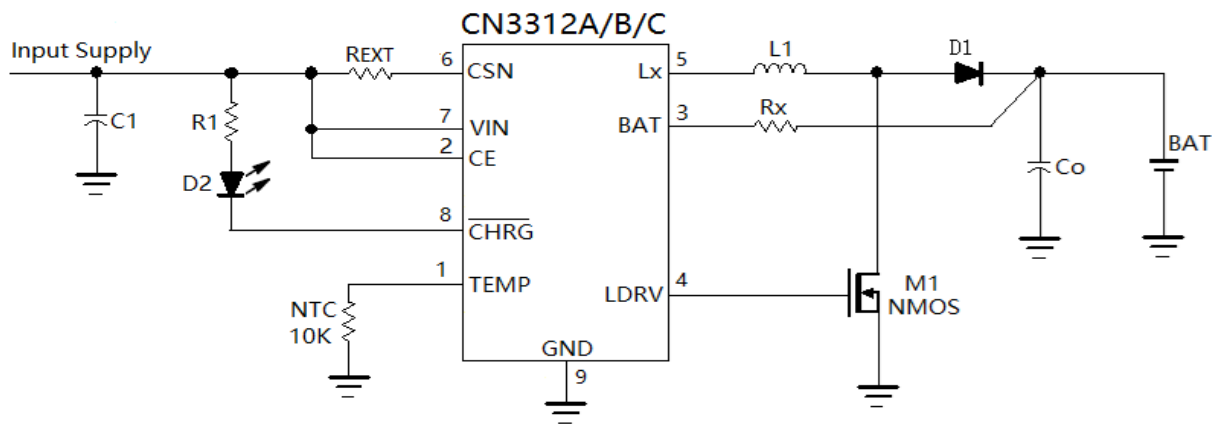

Figure 5 Adjust Charge Termination Voltage upwards

In Figure 5, the resistor R_x is used to adjust the charge termination voltage upwards. Because the resistance characteristics of R_x is different with that of on-chip resistor, it is better that the adjusted amplitude of charge termination voltage is no more than 0.2V.

The adjusted upward voltage amplitude is decided by the following equation:

$$V_x = 4.87 \times 10^{-6} \times R_x \quad (\text{V}), \quad \text{Where, } R_x \text{ is in ohm.}$$

So the actual charge termination voltage is decided by:

$$V_{term} = 8.4 + V_x \quad (\text{V})$$

In case that battery drives inductive loading, R_x can also protect CN3312 from being damaged by the counter electromotive force generated by inductive loading's sudden turning off.

Low Battery or Shorted Battery Protection

In normal operation, the battery voltage is higher than the input voltage. But in some cases, the battery voltage may be lower than input voltage, or even the battery is shorted to Ground. In these cases, CN3312A/B/C operates in linear mode, the external N-channel MOSFET is turned off. CN3312A/B/C controls on-chip P-channel MOSFET to deliver a small current to battery, if the battery voltage is lower than 2V, the charge current will be further reduced.

CONSONANCE

Design Procedures

The following design procedures can be followed to design the parameters of CN3312A/B/C application circuit:

- (1) To determine the charge current based on the battery capacity and the requirement of charge time.
- (2) To decide the input capacitor based on the input supply's characteristics, input supply's cable length and input current.
- (3) To select diode, N-channel MOSFET and P-channel MOSFET based on input voltage, inductor current and the battery's highest voltage.
- (4) To calculate the external current sense resistor R_{CS} if necessary
- (5) To select the output capacitor based on the switching frequency and charge current.

PCB Considerations

A good PCB design is very important to efficiency and performance. When laying out the printed circuit board, the following considerations should be taken to ensure proper operation of the IC.

- If possible, use multi-layer PCB for better performance.
- The ground connections of output capacitor and N-channel MOSFET need to feed into same copper that connects to the input capacitor ground before tying back into system ground. This copper should be as wide as possible, and back to system ground separately.
- To minimize radiation, the diode, MOSFET, inductor and the input bypass capacitor traces should be kept as short as possible. The connection between the diode and the MOSFET should also be kept as short as possible.
- Place the external current sense resistor R_{EXT} , if any, right next to the input capacitor and inductor but oriented such that the IC's $PVIN$ and VIN traces going to R_{EXT} are not long. The 2 traces need to be routed together as a single pair on the same layer at any given time with smallest trace spacing possible.

CONSONANCE

Package Information

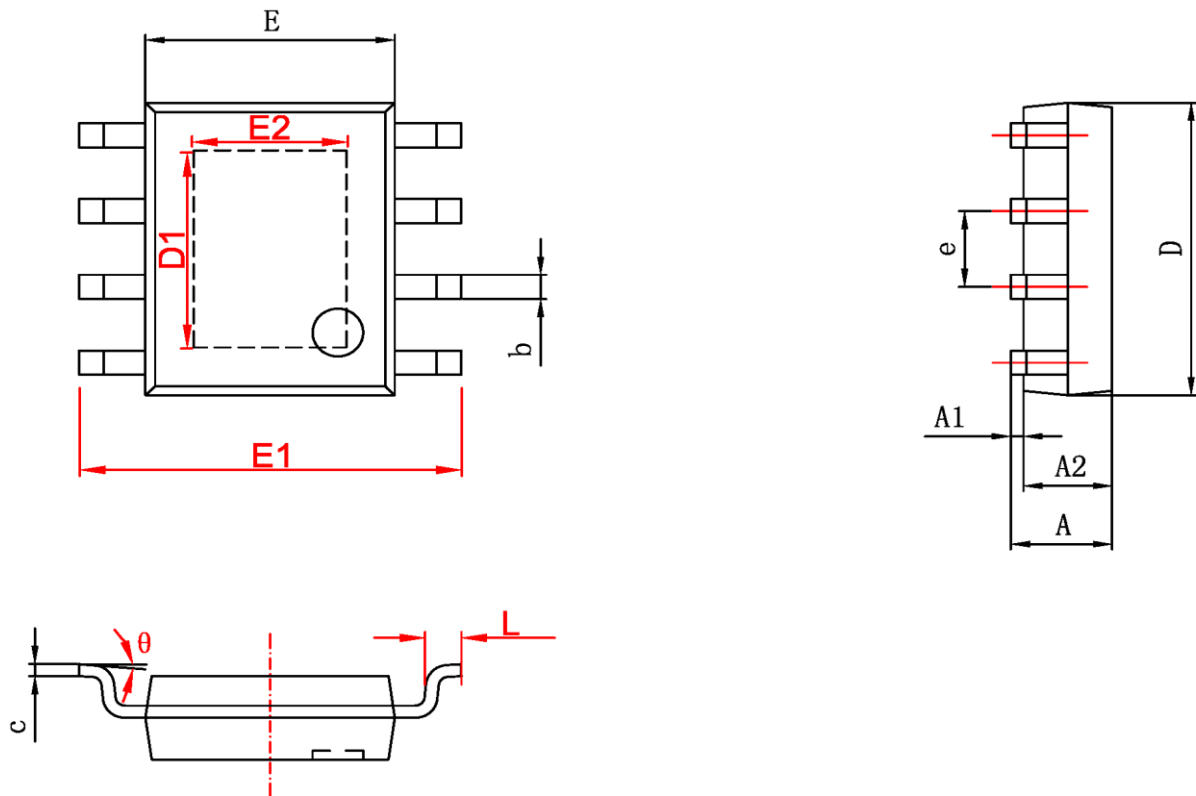

字符	Dimensions In Millimeters		Dimensions In Inches	
	Min	Max	Min	Max
A	1.350	1.750	0.053	0.069
A1	0.050	0.150	0.004	0.010
A2	1.350	1.550	0.053	0.061
b	0.330	0.510	0.013	0.020
c	0.170	0.250	0.006	0.010
D	4.700	5.100	0.185	0.200
D1	3.202	3.402	0.126	0.134
E	3.800	4.000	0.150	0.157
E1	5.800	6.200	0.228	0.244
E2	2.313	2.513	0.091	0.099
e	1.270 (BSC)		0.050 (BSC)	
L	0.400	1.270	0.016	0.050
θ	0°	8°	0°	8°

Important Notice

Consonance Electronics reserves the right to make corrections, modifications, enhancements, improvements and other changes to its products and specifications at any time without notice.

Consonance Electronics assumes no liability for applications assistance or technique support or the use of any circuitry described in the specification during customer product designing and developing. Customers are solely responsible for their products and applications using Consonance Electronics products. Customer should provide adequate design, test and operating safeguard based on its products' operating environment and conditions.