

PFM Step-up 3-cell Lithium Battery Charger IC CN3303

General Description:

CN3303 is a PFM mode step-up battery charge management IC with operating voltage range between 2.7V to 6.5V. It is specially designed for 3-cell lithium battery charge management with fewer external components. CN3303 adopts constant current and quasi-constant voltage(Quasi-CV™) mode to charge battery.

On power up, CN3303 enters charging state, the external N-channel MOSFET is turned on, inductor current rises. When inductor current reaches upper threshold, the N-channel MOSFET is turned off, inductor is discharged, the energy stored in inductor is transferred to battery. When the inductor current is discharged to its lower threshold, the N-channel MOSFET is turned on again. When BAT pin voltage reaches 12.6V(Typ.) for the first time, CN3303 enters quasi-CV mode, in which the charge current is reduced. The charge process will not be terminated until BAT voltage reaches 12.6V for the second time. In termination mode, the N-channel MOSFET is turned off. When BAT voltage falls below recharge threshold, the CN3303 enters charge mode again. CN3303's switching frequency can be up to 1MHz, which makes a small-profile inductor usable.

If battery voltage is lower than input voltage by a diode drop, CN3303 will increase the off time to 5us to reduce the charge current as a protection for battery with the joint action of external N-channel and P-channel MOSFET.

The other features include chip enable input, status indication, etc.

CN3303 is available in 8-pin SOP package.

Applications:

- 3-cell Li+ Battery Charging Management
- Beauty Apparatus
- Audio System
- Standalone Charger

Features:

- Input Voltage Range: 2.7V to 6.5V
- Operating Current: 280uA@VIN=5V
- Inductor Current Detection
- Switching Frequency up to 1MHz
- Quasi-CV mode to Compensate for the Voltage Loss on Battery Internal Resistance and Trace Resistance
- Automatic Recharge
- Output Power up to 35W
- Protection for Low Battery Voltage and Short Battery
- Automatic Adaptability to Input Supply with Limited Driving Capability
- Chip Enable Input
- Battery Overvoltage Protection
- Status Indication
- Operating Temperature : -40°C to 85°C
- Available in SOP8 Package
- Lead-free, rohs-Compliant and Halogen Free

Pin Assignment

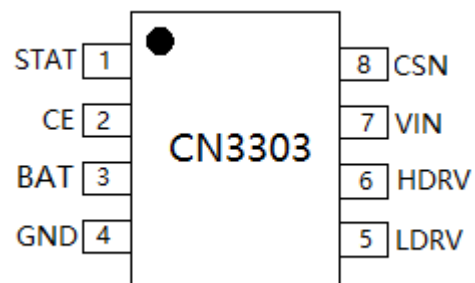

Note: Quasi-CV is the trade mark of
Consonance Electronics

CONSONANCE

Typical Application Circuit:

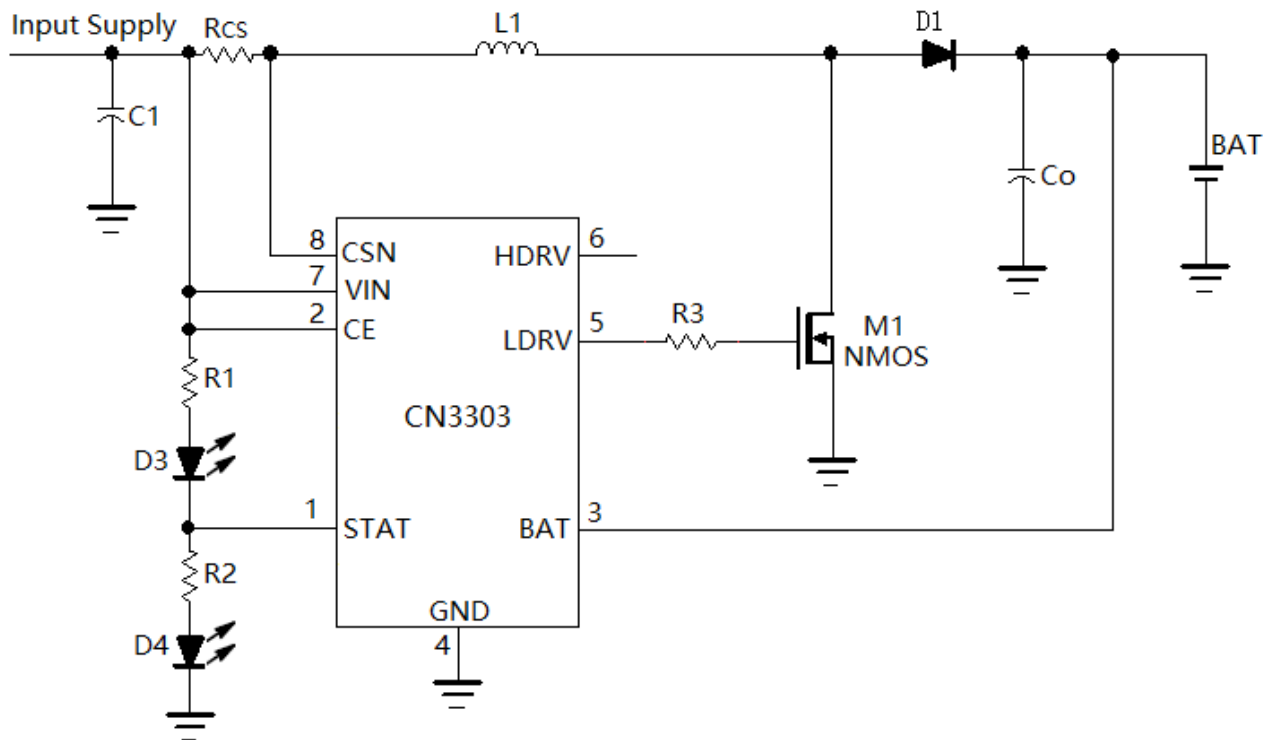

Figure 1 Typical Application Circuit (No protection for low or short battery)

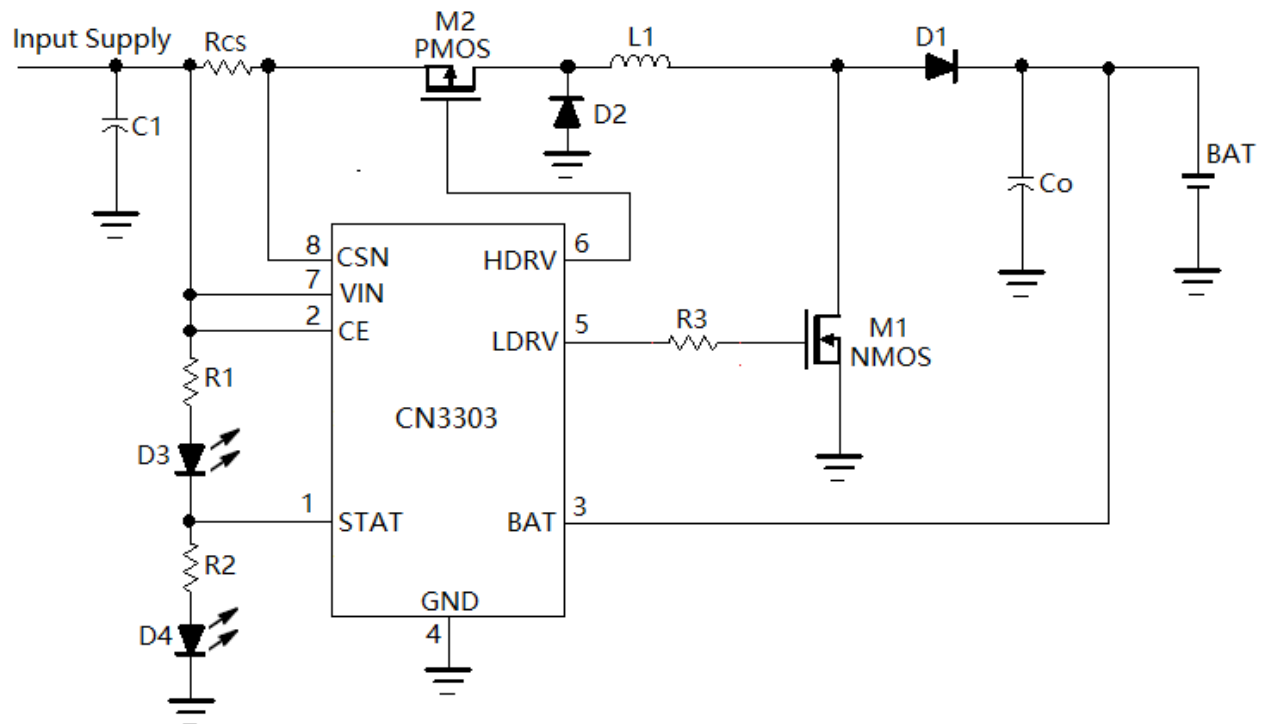

Figure 2 Typical Application Circuit (Protection for low or short battery)

CONSONANCE

Ordering Information:

Part No.	Package	Shipping	Operating Temperature
CN3303	SOP-8	Tape and Reel, 4000/reel	-40°C to 85°C

Block Diagram:

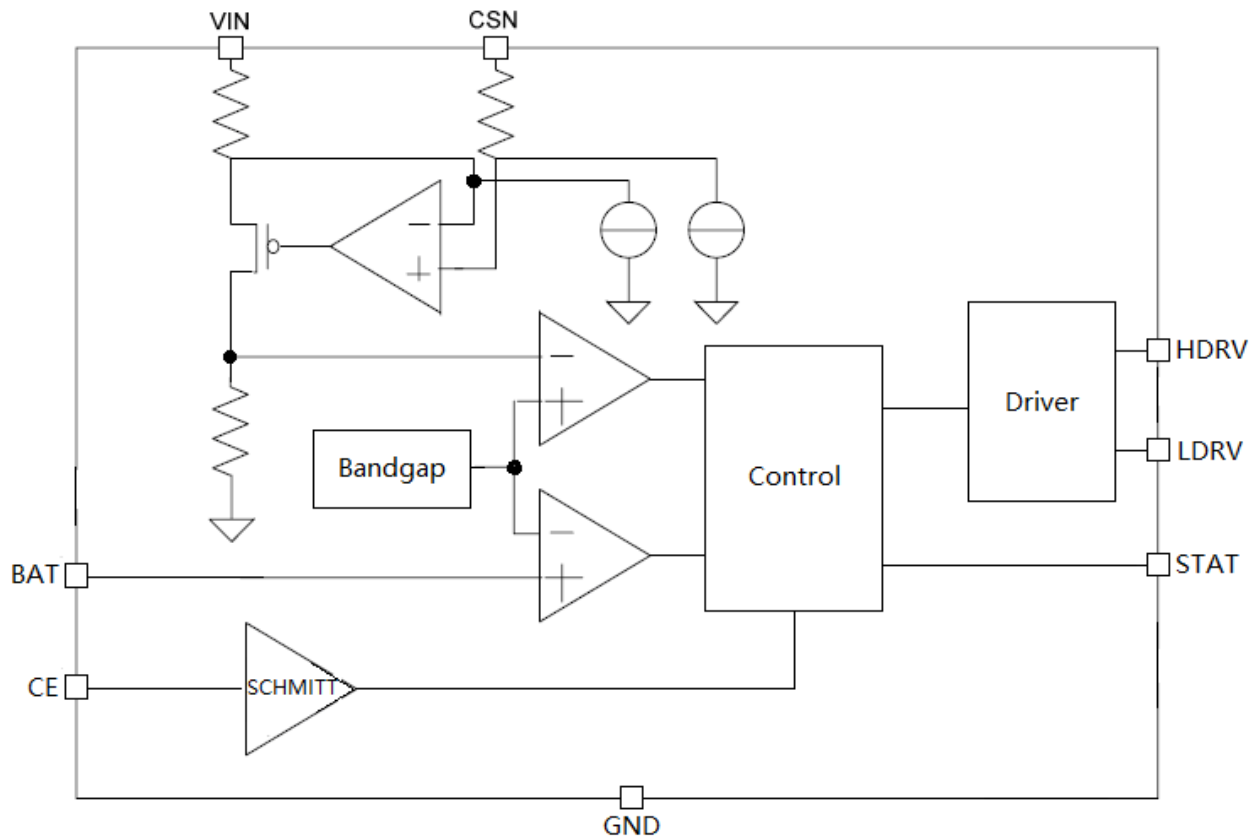

Figure 3 Block Diagram

CONSONANCE

Pin Description:

No.	Symbol	Description
1	STAT	Status Indication Output. CMOS output. STAT pin's being high means charger is in charging state; and charger is in termination state when STAT pin is low.
2	CE	Chip Enable Input. A high input will put the device in the normal operating mode. Pulling the CE pin to low level will put the CN3303 into disable mode. The CE pin can be driven by TTL or CMOS logic level.
3	BAT	Battery Positive Terminal. BAT pin should be tied to battery's positive terminal to monitor battery voltage.
4	GND	GND. Ground, namely the negative terminal of input supply and battery.
5	LDRV	Gate Drive for external N-Channel MOSFET. Connect LDRV pin to the gate of external N-Channel MOSFET.
6	HDRV	Gate Drive for external P-Channel MOSFET. Connect HDRV to the gate of external P-Channel MOSFET. If there is no need to consider the cases such as battery voltage being lower than input supply or short battery, then the P-Channel MOSFET is not needed, and leave HDRV pin floating.
7	VIN	Positive Terminal of Input Supply. CN3303's internal circuit is powered by this pin, VIN is also the positive terminal of inductor current sensing.
8	CSN	Negative Terminal of Inductor Current Sensing. A current sense resistor R_{CS} between VIN pin and CSN pin is used to sense inductor current, also the input current. In constant current mode, $(VIN - CSN)$ is regulated between 85mV and 125mV.

ABSOLUTE MAXIMUM RATINGS

VIN, CSN and CE Voltage.....	-0.3V to 7.0V	Maximum Junction Temperature.....	150°C
BAT Voltage.....	-0.3V to 18V	Operating Temperature Range.....	-40°C to 85°C
CSN and VIN Voltage.....	-0.3V to 0.3V	Storage Temperature.....	-65°C to 150°C
STAT, LDRV and HDRV Voltage.....	-0.3V to VIN	Lead Temperature(Soldering, 10s).....	260°C

Stresses beyond those listed under "Absolute Maximum Ratings" may cause permanent damage to the device. These are stress ratings only, and functional operation of the device at these or any other conditions beyond those indicated in the operational sections of the specifications is not implied. Exposure to absolute maximum rating conditions for extended periods may affect device reliability.

CONSONANCE

ELECTRICAL CHARACTERISTICS:

(VIN = 5V, TA = -40°C to +85°C, Typical values are at TA = +25°C, unless otherwise noted)

Parameters	Symbol	Test Conditions	Min	Typ.	Max	Unit	
Input Voltage Range	VIN		2.7		6.5	V	
UVLO Threshold	VUVLO				2.65	V	
Operating Current	IVIN	V _{BAT} = 13V, No Switching	200	280	360	uA	
Turn-off Current	I _{off}	CE is Low		0	2	uA	
Switching	f _{sw}		200		1000	KHz	
Inductor Current Sense Comparator							
Sense Threshold High	V _{CSHI}	CC	(VIN - V _{CSN}) rises from 0V until	113	123	133	mV
		Quasi-CV	V _{LDRV} < 0.5V	65	75	85	
Sense Threshold Low	V _{CSLO}	CC	(VIN - V _{CSN}) falls from 0.2V till	77	87	97	mV
		Quasi-CV	V _{LDRV} > (VCC - 0.5V)	32	42	52	
Propagation Delay to Output High	t _{DPDH}	(VIN - V _{CSN}): 0.15V to 0.075V		72		ns	
Propagation Delay to Output Low	t _{DPDL}	(VIN - V _{CSN}): 0.06V to 0.135V		66		ns	
CSN Input Current	I _{CSN}				1	uA	
BAT Pin							
Charge Termination Threshold	V _{term}	BAT voltage rises	12.478	12.6	12.726	V	
Recharge Threshold	V _{rech}	BAT voltage falls	11.95	12.14	12.33	V	
BAT Pin Current	I _{BAT}	V _{BAT} = 12.6V	10	14	18	uA	
Over Voltage Threshold	V _{OV}	BAT voltage rises	1.044	1.0663	1.088	% V _{term}	
Over Voltage Release Threshold	V _{OVRLS}	BAT voltage falls	1.003	1.0249	1.047		
LDRV Pin							
LDRV Source Current		V _{CSN} = VIN, V _{DRV} = 0.5 × VCC		0.65		A	
LDRV Sink Current		V _{CSN} = VIN - 0.2V, V _{LDRV} = 0.5 × VCC		0.65		A	
LDRV Output High	V _{OH}	I _{LDRV} = 5mA	VCC - 0.3			V	
LDRV Output Low	V _{OL}	I _{LDRV} = -5mA			0.3	V	
HDRV Pin							
HDRV Source Current		V _{CSN} = VIN - 0.2V, BAT Short to GND, V _{HDRV} = 0.5 × VCC		0.8		A	
HDRV Sink Current		V _{CSN} = VIN, BAT short to GND, V _{HDRV} = 0.5 × VCC		0.8		A	
HDRV Output High	V _{OH}	I _{HDRV} = 5mA	VCC - 0.3			V	
HDRV Output Low	V _{OL}	I _{HDRV} = -5mA			0.3	V	

CONSONANCE

(Continued from Last Page)

Parameters	Symbol	Test Conditions	Min	Typ.	Max	Unit
CE Pin						
Input Low Voltage	V _{CEL}	CE voltage falls			0.7	V
Input High Voltage	V _{CEH}	CE voltage rises	2.2			V
Input Current	I _{CEL}	CE=GND, V _{IN} =6V	-1			uA
	I _{CEH}	CE=V _{IN} =6V			1	
STAT Pin						
Sink Current	I _{SINK}	V _{STAT} =0.3V, Termination mode		10		mA
Source Current	I _{SRC}	V _{STAT} =4.7V, Charge mode		10		mA

Detailed Description:

The CN3303 is a step up charge management IC for 3-cell lithium batteries with input voltage range from 2.7V to 6.5V.

The CN3303 is composed of reference voltage, inductor current sensing circuit, battery voltage detection circuit, battery over voltage protection circuit, low battery protection, logic control block and MOSFET driver, etc. The CN3303 is ideally suitable for 3-cell lithium batteries charging application with fewer external components. After power-on, CN3303 enters constant current charging mode, STAT pin outputs high to indicate that the charging is ongoing, the external N-channel MOSFET is turned on, the inductor current rises, and the energy stored in the output capacitor is transferred to battery. When the inductor current rises to the upper threshold, the N-channel MOSFET is turned off, the inductor current begins to fall, the energy stored in the inductor is transferred to the battery and the output capacitor. When the inductor current falls to the lower threshold, the external N-channel MOSFET is turned on again, and so forth. The battery voltage is sensed by the on-chip resistor divider. When the battery voltage reaches 12.6V(Typical) for the first time, CN3303 enters quasi-CV mode after deglitching. In quasi-CV mode, the charge current is reduced to 50% of that in constant current mode. When the battery voltage reaches 12.6V(Typical) for the second time, the charging is terminated, the external N-channel MOSFET is turned off, CN3303 enters termination mode, and STAT pin outputs low to indicate the termination mode. In termination mode, there is no current flowing to the battery, when the battery voltage falls to 12.14V(Typical), CN3303 enters constant current mode again.

The highest switching frequency of CN3303 can be up to 1MHz, which makes the lo-profile inductor usable. CN3303 is a step-up charger IC, which means the battery voltage should be higher than the input voltage. In certain extreme cases, the battery voltage may be lower than the input voltage, or even the battery is shorted to GND, if these are the cases, the off-time of the external N-channel MOSFET will be lengthened, hence the charge current is reduced as a kind of protection to the battery.

The other functions include chip enable input (CE pin), battery over voltage protection, etc..

The charge profile is illustrated in Figure 4.

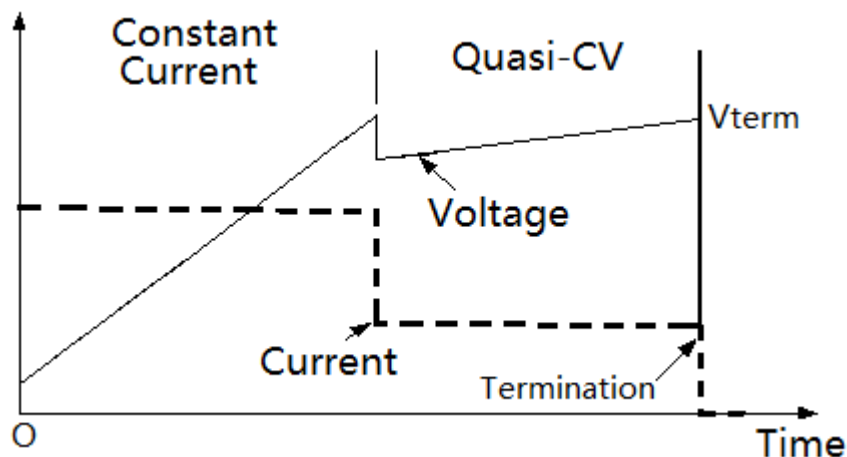

Figure 4 Charging Profile

Application Information:

Input Voltage Range

The CN3303 functions well when the input voltage is between 2.7V to 6.5V. On-chip UVLO circuit will shut down the CN3303 if input voltage falls below UVLO threshold (2.65V Max.).

Chip Enable/Disable

There is a chip enable input CE pin. When the voltage at CE pin is above 2.2V, CN3303 functions normally; When the voltage at CE pin is below 0.7V, CN3303 is turned off. In turn-off state, the operating current is quite small (2uA Max.).

Do not apply a voltage between 0.7V and 2.2V on CE pin, otherwise CN3303 may be in uncertain state.

About Quasi-CV Mode

When the battery voltage is lower than 12.6V, CN3303 charges the battery with constant current. When battery voltage reaches 12.6V(Typical) for the first time, CN3303 enters quasi-CV mode, the charge current is reduced to 50% of that in constant current. When battery voltage reaches 12.6V(Typical) for the second time, CN3303 terminates the charging after deglitching. The quasi-CV mode can compensate for the voltage drop across the battery internal resistance to some extent, which is similar to constant voltage mode, this is why the quasi-CV mode is named.

Inductor Current (Input Current)

In the application circuit shown in Figure 1 and Figure 2, inductor current is sensed via the resistor R_{CS} connected between VIN and CSN pin.

When the external N-channel MOSFET is on, inductor current rises, when it reaches the upper threshold:

$$I_{Lhigh} = 0.123V / R_{CS} \quad (\text{CC Mode})$$

$$I_{Lhigh} = 0.075V / R_{CS} \quad (\text{Quasi-CV Mode})$$

The N-channel MOSFET is turned off.

When the external N-channel MOSFET is off, inductor current falls, the energy is transferred to battery from inductor. When inductor current falls to:

$$I_{Llow} = 0.087V / R_{CS} \quad (\text{CC Mode})$$

$$I_{Llow} = 0.042V / R_{CS} \quad (\text{Quasi-CV})$$

The external N-channel MOSFET is turned on again, a new cycle is started.

So the average inductor current is: $I_L = 0.105V / R_{CS}$ (CC Mode)

$$I_L = 0.06V / R_{CS} \quad (\text{Quasi-CV})$$

CONSONANCE

In the above 3 equations,

I_{Lhigh} is upper threshold of inductor current in Ampere

I_{Llow} is lower threshold of inductor current in Ampere

R_{CS} is the inductor current sense resistor in ohm (Ω)

Calculate Switching Frequency and Inductor

In the application circuit shown in Figure 1 and Figure 2, the on-time of external N-channel MOSFET is:

$$t_{on} = \frac{0.04 \times L}{V_{IN} \times R_{CS}} \text{ --- (1)}$$

The off-time of the N-channel MOSFET is:

$$t_{off} = \frac{0.04 \times L}{(V_{BAT} + V_D - V_{IN}) \times R_{CS}} \text{ --- (2)}$$

So the switching frequency is:

$$f_{sw} = \frac{1}{t_{on} + t_{off}} = \frac{1}{\frac{0.04 \times L}{V_{IN} \times R_{CS}} + \frac{0.04 \times L}{(V_{BAT} + V_D - V_{IN}) \times R_{CS}}}$$

CN3303 requires that the minimum switching frequency is no less than 200KHz. A frequency between 200KHz and 600KHz can achieve a good balance between efficiency and inductor size.

The switching frequency varies with input voltage and battery voltage, so when determining the switching frequency, the nominal battery voltage of 11.1V battery should be used.

Based on the requirements of input voltage range, charge current and switching frequency, the inductor value varies between 2.2uH and 15uH.

The duty cycle of CN3303 LDRV pin:

$$D = \frac{t_{on}}{t_{on} + t_{off}} = \frac{V_{BAT} + V_D - V_{IN}}{V_{BAT} + V_D}$$

In the above 2 equations:

L is the inductor value in Henry(H)

V_{IN} is the input voltage in Volt

V_{BAT} is battery voltage in Volt

V_D is the forward voltage drop of diode in Volt

R_{CS} is the inductor current sense resistance in ohm(Ω)

Estimate Charge Current in Constant Current Mode

CN3303 controls charge current by monitoring inductor current, so the charge current in CC mode may vary with the input voltage and battery voltage.

Normally the following equation can be used to estimate the charge current:

$$I_{CH} = \frac{V_{IN} \times I_L \times \eta}{V_{BAT}}$$

Where,

I_{CH} is charge current in Ampere

V_{IN} is input voltage in Volts

I_L is the average inductor current in Ampere, and decided by $0.106 / R_{CS}$

CONSONANCE

η is the conversion efficiency varying between 80% and 93%.

V_{BAT} is battery voltage in Volt

Charge Termination

When BAT pin voltage reaches 12.6V(Typical) in Quasi-CV state, the charging is terminated, the external N-channel MOSFET is turned off, no current flows to battery.

Recharge

In charge termination state, if voltage at BAT pin falls below 12.14V(Typical), CN3303 enters recharge state.

Selection of N-Channel MOSFET

The CN3303's gate driver is capable of sourcing 0.65A and sinking 0.65A of current. MOSFET selection is based on the maximum battery voltage, inductor current and operating switching frequency. Choose an N-channel MOSFET that has a higher breakdown voltage than the maximum battery voltage, low $R_{ds(ON)}$, and low total gate charge(Qg) for better efficiency. MOSFET threshold voltage must be adequate if operated at the low end of the input-voltage operating range.

Selection of Free-Wheeling Diode

The forward voltage of the freewheeling diode (D1 in Fig.1 and Fig.2) should be as low as possible for better efficiency. A Schottky diode is a good choice as long as the breakdown voltage is high enough to withstand the maximum battery voltage. The forward current rating of the diode must be at least equal to the maximum charge current.

D2 in Fig.2 is only used when the input voltage is higher than battery voltage, in this case the inductor current is lowered much, and the maximum voltage applied on the diode is input voltage, so most of the schottky diodes can be used for D2.

Input Capacitor

In most applications, a bypass capacitor at VIN is needed. An at least 4.7uF ceramic capacitor, placed in close proximity to VIN and GND pins, works well. In some applications depending on the power supply characteristics and cable length, it may be necessary to increase the capacitor's value. The capacitor's breakdown voltage should be higher than the maximum input voltage.

Generally a capacitor between 4.7uF and 47uF works well, ceramic capacitor of X5R or X7R is highly recommended.

Output Capacitor

A filter capacitor (C_o in Figure 1 and Figure 2) is needed between battery positive terminal and ground, the capacitor also supply energy to battery when the N-channel MOSFET is in on state.

The output capacitance is determined by the requirement of output ripple voltage. The ripple voltage is decided by the following equation:

$$\Delta V_{BAT} = \frac{I_{CH} \cdot t_{off}}{C_o} + \frac{0.04 \cdot I_{esr}}{R_{cs}}$$

Where, I_{CH} is the charge current flowing into battery

t_{off} is the off time of N-channel MOSFET

C_o is the output capacitance

r_{esr} is the equivalent series resistance of output capacitor

R_{cs} is the inductor current sense resistor shown in Figure 1 and Figure 2

So the ESR of the output capacitor should be as small as possible, X5R or X7R ceramic capacitors are recommended.

Status Indication

CN3303's CMOS output STAT pin is for status indication. In charge state, STAT pin outputs high; In charge

CONSONANCE

termination state, STAT pin outputs low.

STAT pin can drive LEDs directly or interface with MCU.

In the application circuit shown in Figure 1 and Figure 2, STAT pin is driving LEDs.

When STAT pin interfaces with MCU, if CN3303's operating voltage is higher than MCU's power supply, then the circuit shown in Figure 5 can be used:

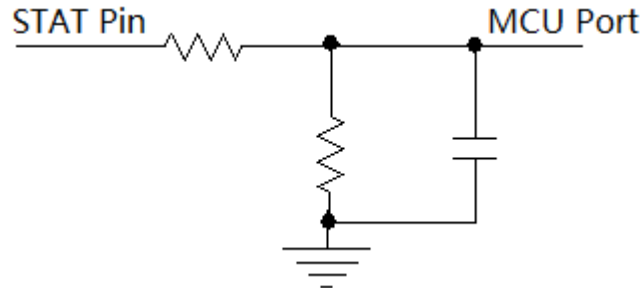

Figure 5 STAT Pin Interfaces with MCU

If 2 common-anode or common-cathode LEDs are to be driven, then the circuits in Figure 6 can be used.

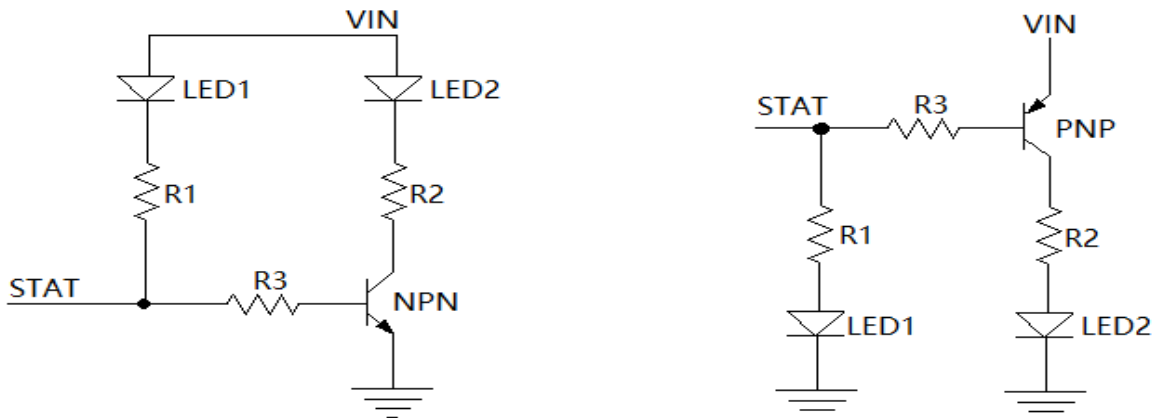

Figure 6 Drive 2 common-anode or common-cathode LEDs

When chip enable input is low, STAT pin outputs high, the LED for charge indication will be turned on. To turn off the LED when CE is low, the circuit in Figure 7 can be used.

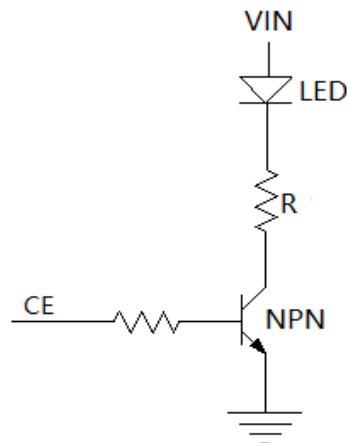

Figure 7 To Turn off LED when CE is low

CONSONANCE

Adjust Charge Termination Voltage upwards

The charge termination voltage can be adjusted upwards by placing a resistor between output and CN3303's BAT pin as shown in Figure 8.

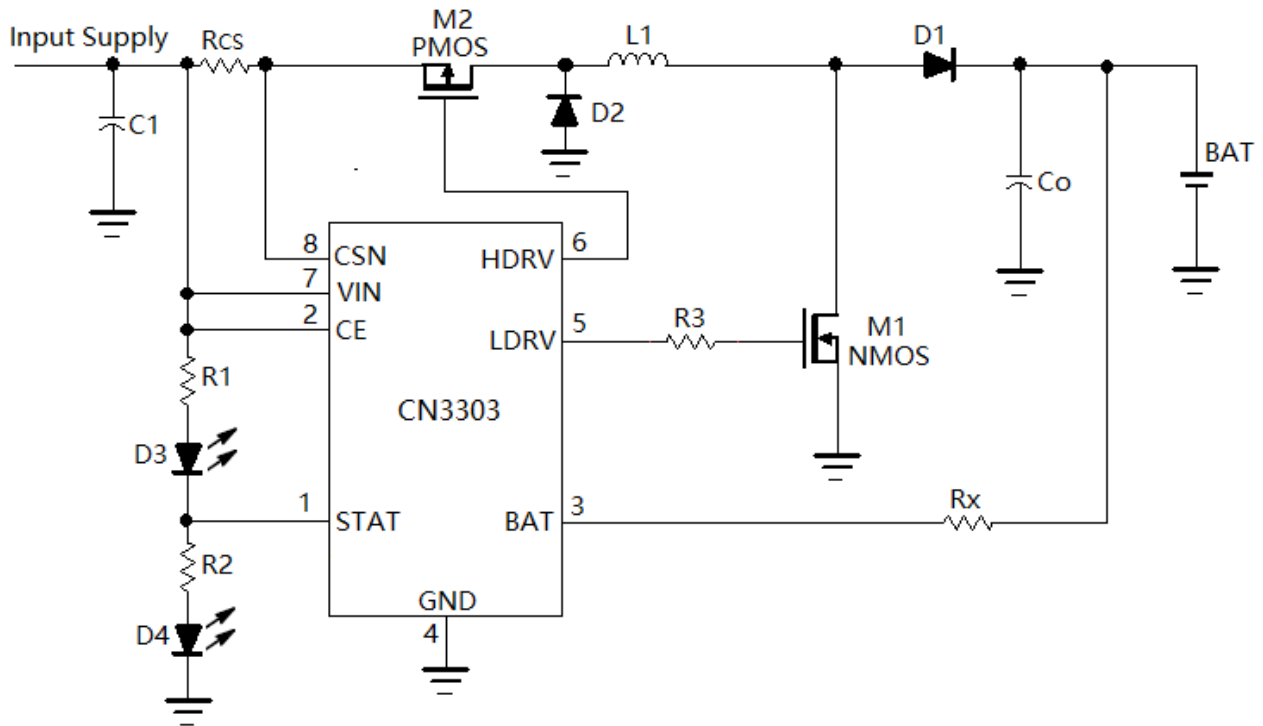

Figure 8 Adjust Charge Termination Voltage upwards

In Figure 8, the resistor Rx is used to adjust the charge termination voltage upwards. Because the resistance characteristics of Rx is different with that of on-chip resistor, it is better that the adjusted amplitude of charge termination voltage is no more than 0.2V.

The adjusted upward voltage amplitude is decided by the following equation:

$$V_x = 13.7 \times 10^{-6} \times R_x \quad (\text{V})$$

So the actual charge termination voltage is decided by:

$$V_{\text{term}} = 12.6 + V_x \quad (\text{V})$$

Low Battery or Shorted Battery Protection

In normal operation, the battery voltage is higher than the input voltage. But in some cases, the battery voltage may be lower than input voltage, or even the battery is shorted to Ground. In these cases, the application circuit shown in Figure 2 should be adopt, otherwise the uncontrolled current may be flowing from input supply to the battery through the inductor and diode, which may be harmful to battery.

Self-adaptive Function to Input Supply

CN3303 can adjust the inductor current automatically to adapt the input supply's output capability. This feature makes it possible that the circuit design can be done based on the adaptor with strong output capability for quick charge purpose, while the adaptor with weaker output capability can also be used for charge purpose.

In self-adaptive mode, the input voltage may falls below 2.4V, so the external MOSFETs should be selected in such a way that they are fully turned on at about 2.4V.

Design Procedures

The following design procedures can be followed to design the parameters of CN3303 application circuit:

- (1) To determine the charge current based on the battery capacity and the requirement of charge time.
- (2) To estimate the input current based on the input voltage range and charge current. The input current is

CONSONANCE

also the inductor current.

- (3) To decide the input capacitor based on the input supply's characteristics, input supply's cable length and input current.
- (4) To select diode, N-channel MOSFET and P-channel MOSFET based on input voltage, inductor current and the battery's highest voltage.
- (5) To calculate the current sense resistor R_{CS} based on the average inductor current
- (6) To determine the inductor value according to the switching frequency. The switching frequency can be from 200KHz to 1MHz. Generally speaking, a switching frequency between 300KHz and 600KHz can achieve a good balance between efficiency and inductor's profile.
- (7) To select the output capacitor based on the switching frequency and charge current.

Design Example

The circuit parameters for Figure 1 and Figure 2 are shown in the following table for some typical scenarios. The circuit parameters are designed based on typical conditions without considering the specific application conditions and the environmental factors. The circuit parameters shown in the table are for reference only.

($V_{IN}=5V$, $V_{term}=12.6V$, I_{CH} is charge current, unless otherwise specified)

	$I_{CH}=0.5A$	$I_{CH}=1A$	$I_{CH}=2A$	$I_{CH}=3A$	$I_{CH}=4A$
Inductor Current	1.35A	2.7A	5.4A	8.1A	10.8A
Input Cap C1	10uF,0805	22uF,1206	22uF,1206 2X in parallel	22uF,1206 3X in parallel	22uF,1206 4X in parallel
Diode D1	SS24 or SS34	SS24 or SS34	SS24 or SS34	SS54 or 1N5824	SS54 or 1N5824
Diode D2	SS24 or SS34	SS24 or SS34	SS24 or SS34	SS34	SS34
NMOS M1	SI2300,SI2302	AO4468	AO4468, AO4410	AO4410, NCE3018S	AON7140
PMOS M2	SI2301,SI2305	AO4435	AO4435	AO4407A	AO4407A
Current Sense Resistor R_{CS}	80m Ω , 0.15W	40 m Ω , 0.25W	20 m Ω , 0.5W	13 m Ω , 1W	10 m Ω , 1W
Inductor L1	10uH, $I_{SAT}>2A$	6.8uH, $I_{SAT}>3A$	3.3uH, $I_{SAT}>5A$	2.2uH, $I_{SAT}>7.5A$	2.2uH, $I_{SAT}>7.5A$
Switching Frequency	568KHz	420KHz	430KHz	420KHz	310KHz
Output Cap Co	10uF,0805	22uF,1206	22uF,1206 2X in parallel	22uF,1206 3X in parallel	22uF,1206 4X in parallel

About EMI Reduction

EMI performance is highly dependent on the circuit design, component selection and PCB design, etc.

CN3303's LDRV pin adopts good drive capability to meet the requirement of outputting 35W power. If the LDRV's rise time and fall time is very short due to small Qg of external N-channel MOSFET, which may bring high frequency EMI. In these cases, a resistor(R3 in Figure 1 and Figure 2) can be used to reduce EMI.

R3's resistance should be chosen such that LDRV's rise time and fall time are at about 60ns, no more than 80ns.

PCB Considerations

A good PCB design is very important to efficiency and performance. When laying out the printed circuit board, the following considerations should be taken to ensure proper operation of the IC.

- If possible, use multi-layer PCB for better performance.
- The ground connections of output capacitor, N-channel MOSFET, and catch diode (D2 in Figure 2) need to feed into same copper that connects to the input capacitor ground before tying back into system ground. This copper should be as wide as possible, and back to system ground separately.

CONSONANCE

- To minimize radiation, the 2 diodes, MOSFETs, inductor and the input bypass capacitor traces should be kept as short as possible. The connection between the diode and the MOSFETs should also be kept as short as possible.
- Place the inductor current sense resistor R_{CS} right next to the input capacitor and inductor but oriented such that the IC's CSN and VIN traces going to R_{CS} are not long. The 2 traces need to be routed together as a single pair on the same layer at any given time with smallest trace spacing possible.

CONSONANCE

Package Information

SOP8 PACKAGE OUTLINE DIMENSIONS

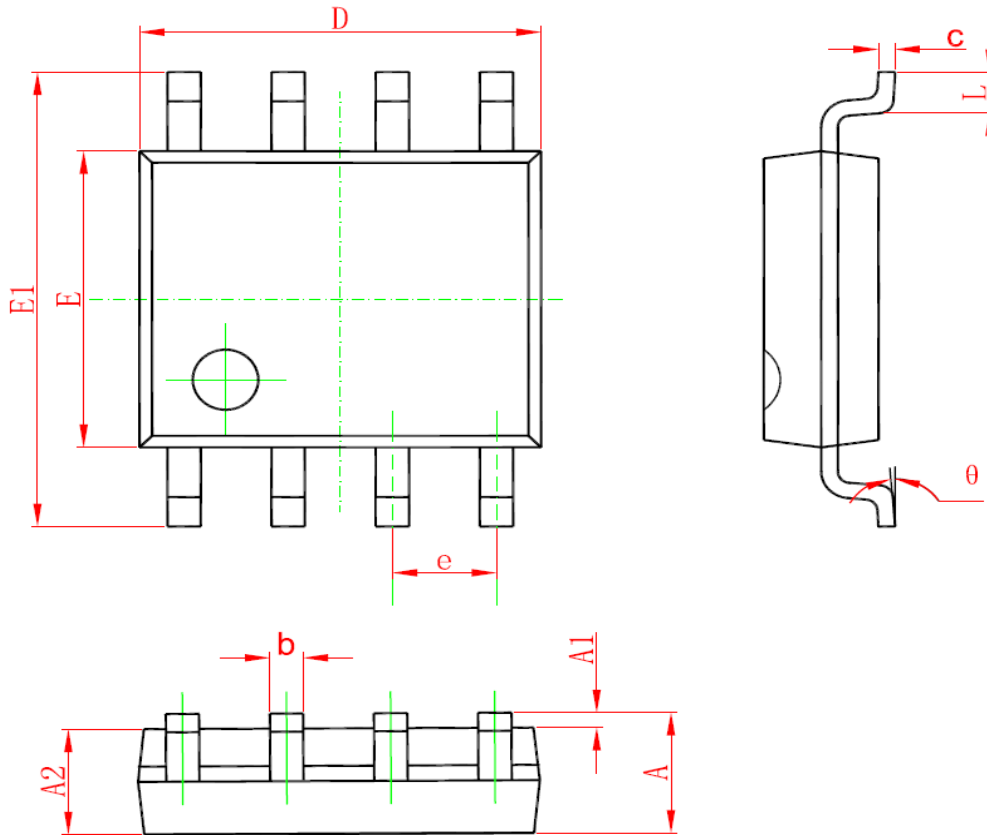

Symbol	Dimensions In Millimeters		Dimensions In Inches	
	Min	Max	Min	Max
A	1.350	1.750	0.053	0.069
A1	0.100	0.250	0.004	0.010
A2	1.350	1.550	0.053	0.061
b	0.330	0.510	0.013	0.020
c	0.170	0.250	0.006	0.010
D	4.700	5.100	0.185	0.200
E	3.800	4.000	0.150	0.157
E1	5.800	6.200	0.228	0.244
e	1.270 (BSC)		0.050 (BSC)	
L	0.400	1.270	0.016	0.050
θ	0°	8°	0°	8°

Consonance Electronics does not assume any responsibility for use of any circuitry described. Consonance Electronics reserves the right to change the circuitry and specifications without notice at any time.