

## 4A, 12V Lead-Acid Battery Charger IC With Photovoltaic Cell MPPT Function CN3767

### General Descriptions:

The CN3767 is a PWM switch-mode battery charger controller for 12V lead-acid battery in a small package using few external components.

The CN3767 is specially designed for charging 12V lead-acid battery with trickle charge, constant current charge, over-charge and float charge mode. In over-charge and float charge mode, the regulation voltage is internally set. The constant charge current is programmable with a single sense resistor. The CN3767 can be powered by solar panel with MPPT function.

Deeply discharged batteries are automatically trickle charged at 17.5% of the programmed constant charge current until the cell voltage exceeds 75% of the regulation voltage in over-charge mode. The over-charge is terminated once the charging current drops to 38% of the constant charge current, then CN3767 will enter into float charge mode. A new charge cycle automatically restarts if the battery voltage falls below 83.95% of the over-charge voltage in float-charge mode. CN3767 will automatically enter sleep mode when input voltage is lower than battery voltage.

Other features include undervoltage lockout and status indication, etc.

CN3767 is available in a space-saving 10-pin SSOP package.

### Applications:

- Lead-Acid Battery Charger
- UPS
- Portable Industrial and Medical Equipment
- Standalone Battery Chargers

### Features:

- Photovoltaic Cell Maximum Power Point Tracking(MPPT)
- Wide Input Voltage: 6.6V to 30V
- Complete Charger Controller for 12V Lead-Acid Battery
- Charge Current Up to 4A
- High PWM Switching Frequency: 300KHz
- Fixed Over-Charge Voltage
- Charging Current is programmed with a sense resistor
- Automatic Conditioning of Deeply Discharged Batteries
- Automatic Recharge
- Charger Status Indication
- Soft Start
- Battery Overvoltage Protection
- Operating Ambient Temperature  $-40^{\circ}\text{C}$  to  $+85^{\circ}\text{C}$
- Available in 10 Pin SSOP Package
- Pb-free , RoHS Compliant, and Halogen Free

### Pin Assignment:

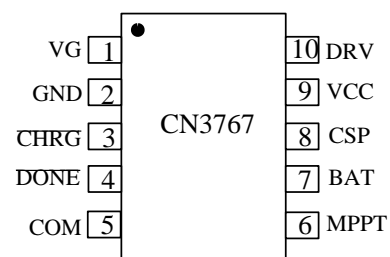

# CONSONANCE

## Typical Application Circuit:

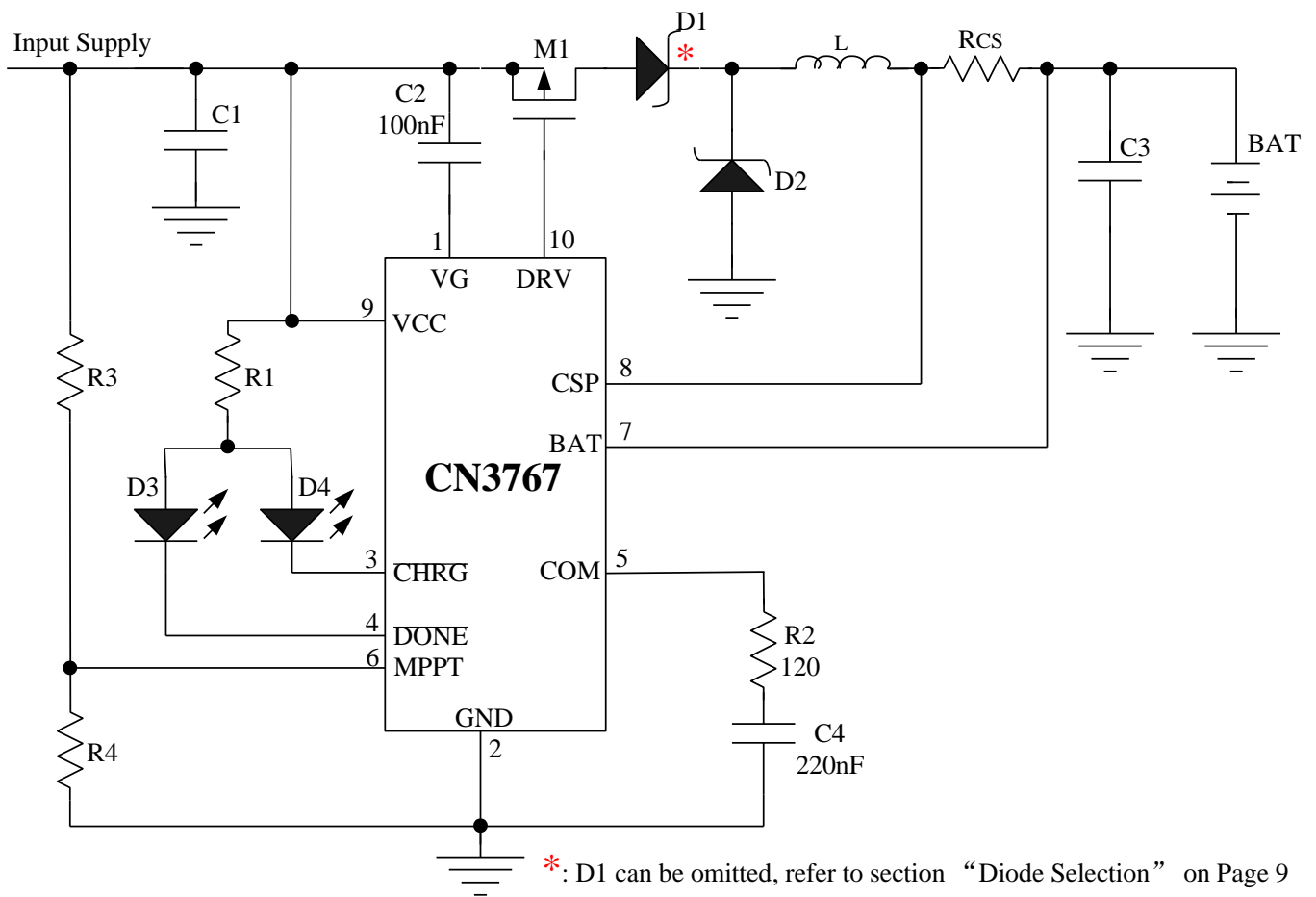

Figure 1 Typical Application Circuit

## Ordering Information:

Part No.	Package Type and Packing	Operating Ambient Temperature
CN3767	SSOP10, Tape and Reel, 2500/Reel	-40°C to +85°C

# CONSONANCE

## Pin Description:

Pin No.	Name	Descriptions
1	VG	<b>Internal Voltage Regulator.</b> VG internally supplies power to gate driver, connect a 100nF capacitor between VG pin and VCC pin.
2	GND	<b>Ground.</b> Negative terminal of input supply.
3	$\overline{\text{CHRG}}$	<b>Open-Drain Charge Status Output.</b> This pin is pulled low by an internal switch if CN3767 is in trickle charge, constant current and over charge mode. In this pin is in high impedance state.
4	$\overline{\text{DONE}}$	<b>Open-Drain Charge Termination Output.</b> When CN3767 is in float charge mode, this pin is pulled low by an internal switch. Otherwise this pin is in high impedance state.
5	COM	<b>Loop Compensation Input.</b> Connect a 220nF capacitor in series with an 120Ω resistor from this pin to GND.
6	MPPT	<b>Photovoltaic Cell Maximum Power Point Tracking Pin.</b> Connect this pin to the external resistor divider for maximum power point tracking. In maximum power point tracking status, the MPPT pin's voltage is regulated to 1.205V.
7	BAT	<b>Negative Input for Charge Current Sensing.</b> This pin and the CSP pin measure the voltage drop across the sense resistor R <sub>CS</sub> to provide the current signals required. Battery voltage is also sensed through BAT pin.
8	CSP	<b>Positive Input for Charge Current Sensing.</b> This pin and the BAT pin measure the voltage drop across the sense resistor R <sub>CS</sub> to provide the current signals required.
9	VCC	<b>External DC Power Supply Input.</b> VCC is also the power supply for internal circuit. Bypass this pin with capacitors.
10	DRV	<b>Gate Drive Pin.</b> Drive the gate of external P-channel MOSFET.

## Absolute Maximum Ratings

Voltage from VCC, CHRG, DONE to GND.....	-0.3V to 33V
Voltage from DRV, VG to VCC.....	-8V to VCC+0.3V
Voltage from CSP, BAT to GND.....	-0.3V to 28V
Voltage from COM, MPPT to GND.....	6.5V
Storage Temperature.....	-65°C---150°C
Operating Ambient Temperature.....	-40°C---85°C
Lead Temperature(Soldering, 10 seconds).....	260°C

*Stresses beyond those listed under 'Absolute Maximum Ratings' may cause permanent damage to the device. These are stress ratings only and functional operation of the device at these or any other conditions above those indicated in the operational sections of the specifications is not implied. Exposure to Absolute Maximum Rating Conditions for extended periods may affect device reliability.*

# CONSONANCE

## Electrical Characteristics:

(VCC=15V, T<sub>A</sub>=-40°C to 85°C, unless otherwise noted)

Parameters	Symbol	Conditions	Min	Typ	Max	Unit	
Input Voltage Range	VCC		6.6		30	V	
Undervoltage lockout Threshold	UVLO		4	5.2	6.5	V	
Operating Current	I <sub>VCC</sub>	V <sub>BAT</sub> > V <sub>OC</sub> (Note1)	0.7	1.0	1.3	mA	
Current Sense Voltage (V <sub>CSP</sub> -V <sub>BAT</sub> )	V <sub>CS</sub>	V <sub>BAT</sub> > 75% × V <sub>OC</sub> (Note1)	113	120	127	mV	
		V <sub>BAT</sub> < 75% × V <sub>OC</sub> (Note1)	11	21	31		
Current into BAT Pin	I <sub>BAT</sub>	V <sub>BAT</sub> = 12V	5	10	15	uA	
Precharge Threshold	V <sub>PRE</sub>	V <sub>BAT</sub> rising		75%		V <sub>OC</sub> (Note1)	
Float charge Voltage	V <sub>Float</sub>	Float charge mode		91.57%			
Recharge Threshold	V <sub>RE</sub>	V <sub>BAT</sub> falling		83.95%			
Overvoltage Trip Level	V <sub>OV</sub>	V <sub>BAT</sub> rising, not in float charge	1.05	1.07	1.09		
		V <sub>BAT</sub> rising, float charge mode	0.96	0.98	1.0		
Overvoltage Clear Level	V <sub>clr</sub>	V <sub>BAT</sub> falling, not in float charge	1.0	1.02	1.04		
		V <sub>BAT</sub> falling, float charge	0.913	0.933	0.953		
<b>Over Charge Mode</b>							
Regulation Voltage	V <sub>OC</sub>	BAT pin , Over Charge mode	14.58	14.8	15.02	V	
<b>Float Charge Mode</b>							
Regulation Voltage	V <sub>FLOAT</sub>	BAT pin , Float Charge mode	13.35	13.55	13.75	V	
<b>MPPT Pin</b>							
MPPT Regulation Voltage	V <sub>MPPT</sub>	Maximum power point track	1.18	1.205	1.23	V	
MPPT Pin Bias Current	I <sub>MPPT</sub>		-100	0	+100	nA	
<b>CHRG Pin</b>							
CHRG Pin Sink Current	I <sub>CHRG</sub>	V <sub>CHRG</sub> =1V, charge mode	7	12	18	mA	
CHRG Leakage Current	I <sub>LK1</sub>	V <sub>CHRG</sub> =25V, Float mode			1	uA	
<b>DONE Pin</b>							
DONE Sink Current	I <sub>DONE</sub>	V <sub>DONE</sub> =1V, Float mode	7	12	18	mA	
DONE Leakage Current	I <sub>LK2</sub>	V <sub>DONE</sub> =25V, charge mode			1	uA	
<b>Oscillator</b>							
Switching Frequency	f <sub>osc</sub>		240	300	360	KHZ	
Maximum Duty Cycle	D <sub>max</sub>			94		%	
<b>Sleep Mode</b>							
Sleep Mode Threshold (measure VCC-V <sub>BAT</sub> )	V <sub>SLP</sub>	VCC falling	V <sub>BAT</sub> =12V	0.0	0.05	0.1	V
Sleep mode Release Threshold (measure VCC-V <sub>BAT</sub> )	V <sub>SLPR</sub>	VCC rising,	V <sub>BAT</sub> =12V	0.2	0.32	0.46	V

# CONSONANCE

(Continued from last page)

Parameters	Symbol	Conditions	Min	Typ	Max	Unit
<b>DRV Pin</b>						
V <sub>DRV</sub> High (VCC-V <sub>DRV</sub> )	VH	I <sub>DRV</sub> = -10mA		60		mV
V <sub>DRV</sub> Low (VCC-V <sub>DRV</sub> )	VL	I <sub>DRV</sub> = 0mA	5	6.3	8	V
Rise Time	t <sub>r</sub>	Cl <sub>oad</sub> = 2nF, 10% to 90%	30	40	65	ns
Fall Time	t <sub>f</sub>	Cl <sub>oad</sub> = 2nF, 90% to 10%	30	40	65	ns

Note 1: V<sub>OC</sub> is the regulation voltage at BAT pin in over-charge mode, which is 14.8V with  $\pm 1.5\%$  accuracy.

## Detailed Description:

The CN3767 is battery charger controller that adopts PWM step-down (buck) switching architecture, the device is specially designed for 12V lead-acid battery with trickle charge, constant current, over voltage and float charge mode. The charge current is set by an external sense resistor (R<sub>CS</sub>) across the CSP and BAT pins. The battery regulation voltage V<sub>REG</sub> in over charge mode is internally set at 14.8V(Typical) with  $\pm 1.5\%$  accuracy. A charge cycle begins when the voltage at the VCC pin rises above the UVLO level and is greater than the battery voltage. At the beginning of the charge cycle, if the battery voltage is less than  $75\% \times V_{oc}$ , the charger goes into trickle charge mode. The trickle charge current is about 17.5% of the full charge current. If the battery voltage rises above  $75\% \times V_{oc}$ , the charger enter constant current mode. In constant current mode, the charge current is set by the internal 0.12V reference voltage and a external resistor R<sub>CS</sub>, the constant current is  $0.120/R_{CS}$ . In constant current mode, CN3767 will go back to trickle charge mode if the battery voltage drops below 75% of the over charge voltage. When the battery voltage approaches the over-charge voltage, the charger goes into the over charge mode. In over charge mode, the charge current start to decrease and when the charge current drops to 38% of constant charge current, the charger goes into float-charge mode, the BAT pin voltage in float-charge mode is regulated at 13.55V(Typical). In trickle charge, constant current and over-charge mode,  $\overline{CHRG}$  pin is pulled low by an internal N-channel MOSFET to indicate that the charge cycle is ongoing, and  $\overline{DONE}$  pin is in high impedance state. During the float-charge mode,  $\overline{DONE}$  pin is pulled low by an internal N-channel MOSFET to indicate the float-charge mode, and  $\overline{CHRG}$  pin is in high impedance state.

In float charge mode to restart the charge cycle, just remove and reapply the input voltage. Also, a new charge cycle will begin if the battery voltage drops below the recharge threshold voltage of  $83.95\% \times V_{oc}$ .

When the input voltage is not present, the charger goes into sleep mode.

The CN3767 adopts the constant voltage method to track the photovoltaic cell's maximum power point, hence solar panel can be used to power the charger. The MPPT pin's voltage is regulated to 1.205V to track the maximum power point of the solar panel.

An over-voltage comparator guards against voltage transient overshoots. In this case, P-channel MOSFET is turned off until the overvoltage condition is cleared. This feature is useful for battery load dump or sudden removal of battery.

The charging profile is shown in Figure 2.

# CONSONANCE

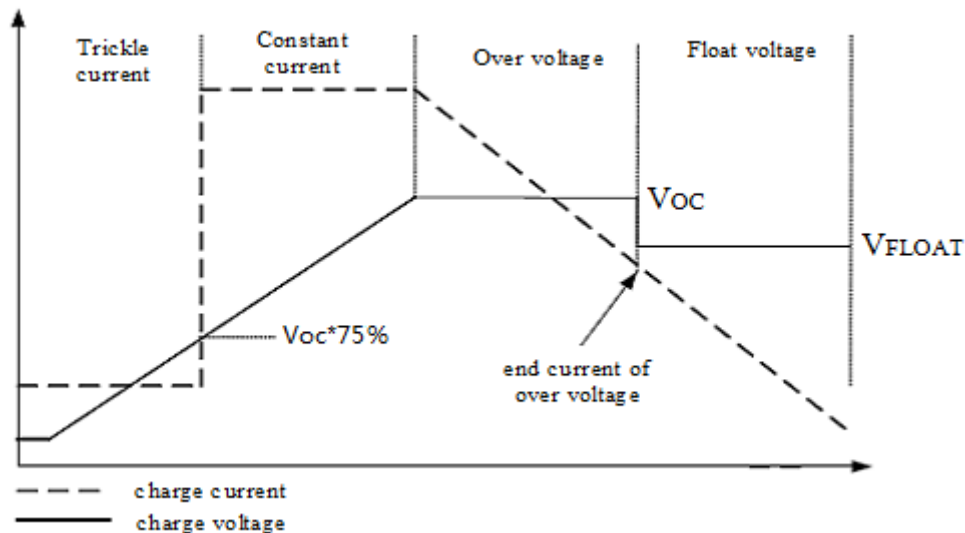

Figure 2 The Charging Profile

## Application Information

### Undervoltage Lockout (UVLO)

An undervoltage lockout circuit monitors the input voltage and keeps the charger off if VCC falls below 5.2V(Typical).

### The Regulation Voltage in Over Voltage Mode and Float Charge Mode

The regulation voltage  $V_{OC}$  at BAT pin in over charge mode is set at 14.8V(Typical) with  $\pm 1.5\%$  accuracy. In float charge mode, the regulation voltage  $V_{FLOAT}$  at BAT pin is 91.57% of that in over charge mode, which is 13.55V(Typical).

### Trickle Charge Mode

At the beginning of a charge cycle, if the battery voltage is below  $75\% \times V_{OC}$ , the charger goes into trickle charge mode with the charge current set at about 17.5% of the constant current.

### Charge Current Setting

The constant charge current, namely the charge current in constant current mode, is decided by the following formula:

$$I_{CH} = \frac{0.12V}{R_{CS}}$$

Where:

$I_{CH}$  is the constant charge current

$R_{CS}$  is the resistor between the CSP pin and BAT pin

### End-of-Over Charge Current

When the battery voltage approaches the over-charge voltage, the charger goes into the over charge mode. In over charge mode, the charge current start to decrease and when the charge current drops to 38% of constant charge current, the charger goes into float-charge mode.

### The Maximum Power Point Tracking

CN3767 adopts the constant voltage method to track the photovoltaic cell's maximum power point. From I-V curve of photovoltaic cell, under a given temperature, the photovoltaic cell's voltages at the maximum power point are nearly constant regardless of the different irradiances. So the maximum power point can be tracked if the photovoltaic cell's output voltage is regulated to a constant voltage.

# CONSONANCE

CN3767's MPPT pin's voltage is regulated to 1.205V to track the maximum power point working with the off-chip resistor divider(R3 and R4 in Figure 1).

The maximum power point voltage of the photovoltaic cell is decided by the following equation:

$$V_{MPPT} = 1.205 \times (1 + R3 / R4)$$

## Float Charge Mode

After the over voltage charge is terminated, the charger goes into float charge mode. In float charge mode, the battery voltage is regulated to  $91.57\% \times V_{OC}$ , namely 13.55V(Typical). Float charge mode can compensate for the loss of battery power due to self-discharge or external loading.

## Automatic Battery Recharge

In float mode, if both the battery and the input power supply (wall adapter) are present, a new charge cycle will begin if the battery voltage drops below  $83.95\% \times V_{OC}$  due to self-discharge or external loading.

A new charge cycle can also be started manually by plugging off the input supply and reapplying it.

## Status Indication

The CN3767 has 2 open-drain status outputs:  $\overline{CHRG}$  and  $\overline{DONE}$ .  $\overline{CHRG}$  is pulled low when the charger is in trickle charge mode, constant current mode and over charge mode,  $\overline{DONE}$  is in high impedance state.

In float mode,  $\overline{CHRG}$  becomes high impedance.  $\overline{DONE}$  is pulled low.

When the battery is not present, the charger charges the output capacitor to the float-charge voltage.

The open drain pin that is not used should be tied to ground.

The table 1 lists the two indicator status and its corresponding charging status. It is supposed that red LED is connected to  $\overline{CHRG}$  pin and green LED is connected to  $\overline{DONE}$  pin.

$\overline{CHRG}$ pin	$\overline{DONE}$ pin	State Description
Low(the red LED on)	High Impedance(the green LED off)	Trickle ,constant current or over-charge mode
High Impedance(the red LED off)	Low(the green LED on)	Float mode
High Impedance(the red LED off)	High Impedance(the green LED off)	There are two possible states: <ul style="list-style-type: none"><li>● the voltage at the VCC pin below the UVLO level or</li><li>● the voltage at the VCC pin below <math>V_{BAT}</math></li></ul>

Table 1 Indication Status

## Gate Drive

The CN3767's gate driver can provide high transient currents to drive the external pass transistor. The rise and fall times are typically 40ns when driving a 2000pF load, which is typical for a P-channel MOSFET with  $R_{ds(on)}$  in the range of 50m $\Omega$ .

A voltage clamp is added to limit the gate drive to 8V max. below VCC. For example, if VCC is 20V, then the DRV pin output will be pulled down to 12V min. This allows low voltage P-channel MOSFETs with superior  $R_{ds(on)}$  to be used as the pass transistor thus increasing efficiency.

## Loop Compensation

In order to make sure that the current loop and the voltage loop are stable, a series-connected 220nF ceramic capacitor and 120 $\Omega$  resistor from the COM pin to GND are needed(R2 and C4 in Figure 1).

## Input Capacitor

Since the input capacitor(C1 in Figure 1) is assumed to absorb all input switching ripple current in the converter,

# CONSONANCE

---

it must have an adequate ripple current rating. Worst-case RMS ripple current is approximately one-half of output charge current.

In order to depress the high-frequency oscillation during P-channel MOSFET's turning on and off, it is best that the input capacitor consists of the following 3 capacitors in parallel:

- Electrolytic capacitor for low-frequency filtering
- A ceramic capacitor from 1uF to 10uF
- A high-frequency capacitor from 47nF to 1uF

## Output Capacitor

The selection of output capacitor (C3 in Figure 1) is primarily determined by the ESR required to minimize ripple voltage and load step transients. It is best that the output capacitor consists of the following 2 capacitors in parallel:

- A 10uF electrolytic capacitor for low-frequency filtering
- A ceramic capacitor from 1uF to 10uF

If only ceramic capacitor can be used, care must be taken that some ceramic capacitors exhibit large negative voltage coefficient, which may lead to high voltage at BAT pin when battery is not present. In this case, the capacitor value should be increased properly so that no damage will be done.

## Inductor Selection

During P-channel MOSFET's on time, the inductor current increases, and decreases during P-channel MOSFET's off time, the inductor's ripple current increases with lower inductance and higher input voltage. Higher inductor ripple current results in higher charge current ripple and greater core losses. So the inductor's ripple current should be limited within a reasonable range.

The inductor's ripple current is given by the following formula:

$$\Delta I_L = \frac{1}{f(L)} V_{BAT} \left(1 - \frac{V_{BAT}}{VCC}\right)$$

Where,

f is the switching frequency 300KHz

L is the inductor value

V<sub>BAT</sub> is the battery voltage

VCC is the input voltage

A reasonable starting point for setting inductor ripple current is  $\Delta I_L = 0.3 \times I_{CH}$ , I<sub>CH</sub> is the charge current. Remember that the maximum  $\Delta I_L$  occurs at the maximum input voltage and the lowest inductor value. So lower charge current generally calls for larger inductor value.

In the meantime, inductor value should meet the requirement of the following equation:

$$L > 5 \times (VCC - V_{BAT}) \quad (\mu H)$$

## MOSFET Selection

The CN3767 uses a P-channel power MOSFET switch. The MOSFET must be selected to meet the efficiency or power dissipation requirements of the charging circuit as well as the maximum temperature of the MOSFET.

The peak-to-peak gate drive voltage is set internally, this voltage is typically 6V. Consequently, logic-level threshold MOSFETs must be used. Pay close attention to the BV<sub>DSS</sub> specification for the MOSFET as well; many of the logic level MOSFETs are limited to 30V or less.

Selection criteria for the power MOSFET includes the "on" resistance R<sub>ds(on)</sub>, total gate charge Q<sub>g</sub>, reverse transfer capacitance C<sub>RSS</sub>, input voltage and maximum charge current.

The MOSFET power dissipation at maximum output current is approximated by the equation:



# CONSONANCE

---

$$P_d = \frac{V_{BAT}}{V_{CC}} \times R_{ds(on)} \times I_{CH}^2 \times (1+0.005dT)$$

Where:

$P_d$  is the power dissipation of the power MOSFET

$V_{BAT}$  is the maximum battery voltage

$V_{CC}$  is the minimum input voltage

$R_{ds(on)}$  is the power MOSFET's on resistance at room temperature

$I_{CH}$  is the charge current

$dT$  is the temperature difference between actual ambient temperature and room temperature(25°C)

In addition to the  $I^2R_{ds(on)}$  loss, the power MOSFET still has transition loss, which are highest at the highest input voltage. Generally speaking, for  $V_{IN} < 20V$ , the  $I^2R_{ds(on)}$  loss may be dominant, so the MOSFET with lower  $R_{ds(on)}$  should be selected for better efficiency; for  $V_{IN} > 20V$ , the transition loss may be dominant, so the MOSFET with lower  $C_{RSS}$  can provide better efficiency.  $C_{RSS}$  is usually specified in the MOSFET characteristics; if not, then  $C_{RSS}$  can be calculated using  $C_{RSS} = Q_{GD}/\Delta V_{DS}$ .

The MOSFETs such as AO4459, STM9435(or WT9435), AO3407A can be used. The part numbers listed above are for reference only, the users can select the right MOSFET based on their requirements.

## Diode Selection

The diodes D1 and D2 in Figure 1 are schottky diode, the current rating of the diodes should be at least the charge current limit, the voltage rating of the diode should exceed the maximum expected input voltage.

The diode that is much larger than that is sufficient can result in larger transition losses due to their larger junction capacitance.

Diode D1 in Figure 1 is used as block diode to prevent battery current from flowing back to VCC when input supply is absent. Without D1, CN3767 consumes about 52uA current from battery( $V_{BAT}=12V$ ), so diode D1 can be removed if the 51uA battery current is not a consideration.

## Battery Current In Sleep Mode

In the typical application circuit shown in Figure 1, when input voltage is powered off or lower than battery voltage, CN3767 will enter sleep mode. In sleep mode, the battery current includes:

- (1) The current into BAT pin and CSP pin, which is about 8uA( $V_{BAT}=12V$ ).
- (2) The current from battery to VCC pin via diode D1, which is determined by D1's leakage current.  
If diode D1 is not used, then the current flowing to VCC pin via inductor and body diode of P-channel MOSFET is about 44uA( $V_{BAT}=12V$ ).
- (3) The current from battery to GND via diode D2, which is also determined by D2's leakage current.

# CONSONANCE

## PCB Layout Considerations

When laying out the printed circuit board, the following considerations should be taken to ensure proper operation of the IC.

- (1) To minimize radiation, the 2 diodes, pass transistor, inductor and the input bypass capacitor traces should be kept as short as possible. The positive side of the input capacitor should be close to the source of the P-channel MOSFET; it provides the AC current to the pass transistor. The connection between the diode and the pass transistor should also be kept as short as possible.
- (2) The compensation capacitor connected at the COM pin should return to the ground pin of the IC. This will prevent ground noise from disrupting the loop stability.
- (3) Output capacitor ground and catch diode (D2 in Figure 1) ground connections need to feed into same copper that connects to the input capacitor ground before tying back into system ground.
- (4) Analog ground and power ground(or switching ground) should return to system ground separately.
- (5) The ground pins also works as a heat sink, therefore use a generous amount of copper around the ground pins. This is especially important for high VCC and/or high gate capacitance applications.
- (6) Place the charge current sense resistor  $R_{CS}$  right next to the inductor output but oriented such that the IC's CSP and BAT traces going to  $R_{CS}$  are not long. The 2 traces need to be routed together as a single pair on the same layer at any given time with smallest trace spacing possible.
- (7) The CSP and BAT pins should be connected directly to the 2 terminals of current sense resistor (Kelvin sensing) for best charge current accuracy. See Figure 3 as an example.

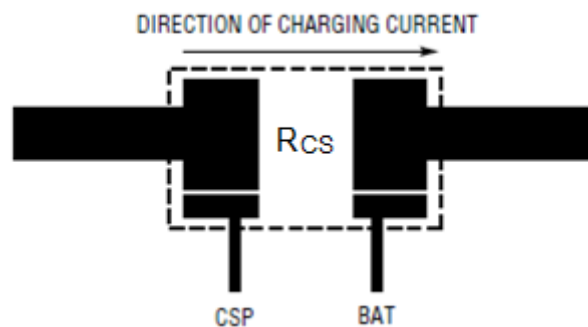
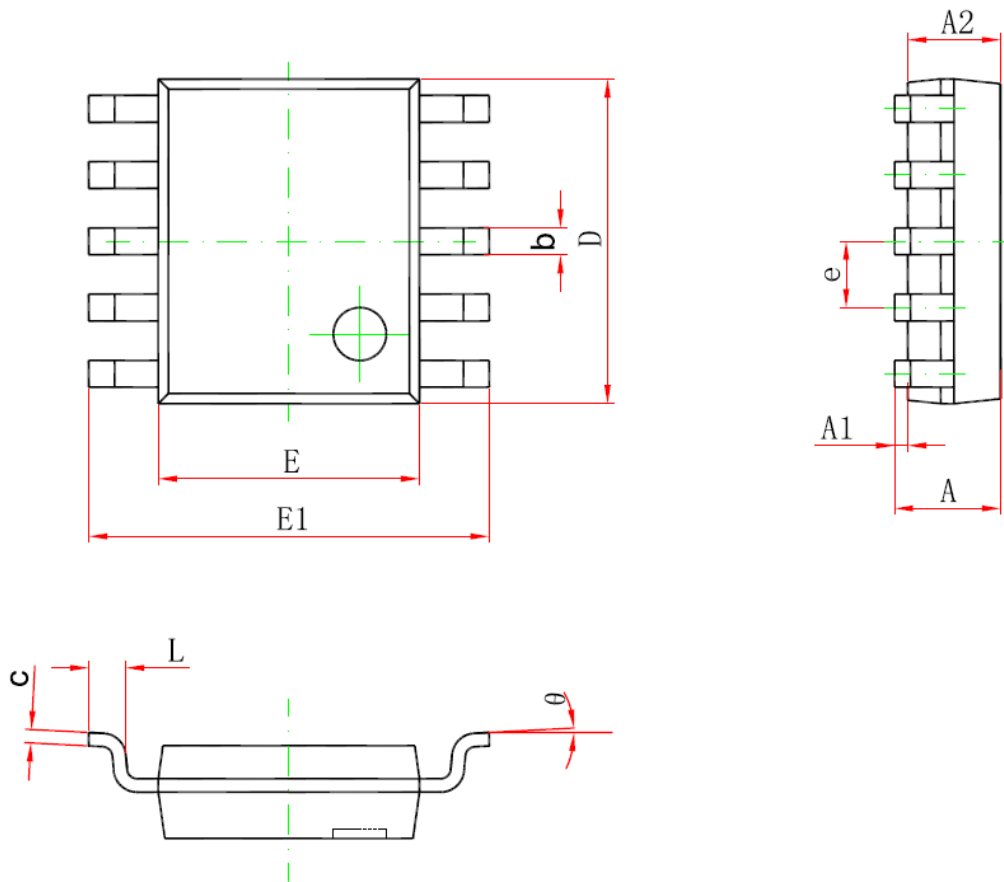

Figure 3 Kelvin Sensing of Charge Current

# CONSONANCE

## Package Information



Symbol	Dimensions In Millimeters		Dimensions In Inches	
	Min	Max	Min	Max
A	1.350	1.750	0.053	0.069
A1	0.100	0.250	0.004	0.010
A2	1.350	1.550	0.053	0.061
b	0.300	0.450	0.012	0.018
c	0.170	0.250	0.007	0.010
D	4.700	5.100	0.185	0.201
E	3.800	4.000	0.150	0.157
E1	5.800	6.200	0.228	0.244
e	1.000 (BSC)		0.039 (BSC)	
L	0.400	1.270	0.016	0.050
θ	0°	8°	1°	8°

Consonance Electronics does not assume any responsibility for use of any circuitry described. Consonance Electronics reserves the right to change the circuitry and specifications without notice at any time.