

4A, Standalone Li-ion Battery Charger IC With Photovoltaic Cell MPPT Function CN3791

General Descriptions:

The CN3791 is a PWM switch-mode lithium ion battery charger controller that can be powered by photovoltaic cell with maximum power point tracking function with few external components.

The CN3791 is specially designed for charging lithium ion batteries with constant current and constant voltage mode. In constant voltage mode, the regulation voltage can be fixed at 4.2V with $\pm 1\%$ accuracy. The constant charge current is programmable with a single current sense resistor. Deeply discharged batteries are automatically trickle charged at 17.5% of the full-scale current until the cell voltage exceeds 66.5% of constant voltage. The charge cycle is terminated once the charge current drops to 16% of full-scale current, and a new charge cycle automatically restarts if the battery voltage falls below 95.5% of regulation voltage. CN3791 will automatically enter sleep mode when input voltage is lower than battery voltage.

Other features include under voltage lockout, battery over voltage protection, status indication. CN3791 is available in a space-saving 10-pin SSOP package.

Applications:

- Power Bank
- Hand-held Equipment
- Battery-Backup Systems
- Portable Industrial and Medical Equipment
- Standalone Battery Chargers

Features:

- Photovoltaic Cell Maximum Power Point Tracking
- Wide Input Voltage: 4.5V to 28V
- Complete Charge Controller for single cell Lithium-ion Battery
- Charge Current Up to 4A
- High PWM Switching Frequency: 300KHz
- Constant Voltage: 4.2V $\pm 1\%$
- Charging Current is programmed with a current sense resistor
- Automatic Conditioning of Deeply Discharged Batteries
- Automatic Recharge
- Charging Status Indication
- Soft Start
- Battery Overvoltage Protection
- Operating Ambient Temperature -40°C to $+85^{\circ}\text{C}$
- Available in 10 Pin SSOP Package
- Pb-free, Rohs-Compliant, Halogen Free

Pin Assignment:

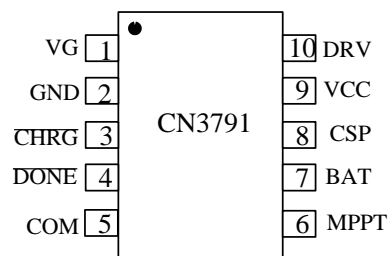

CONSONANCE

Typical Application Circuit:

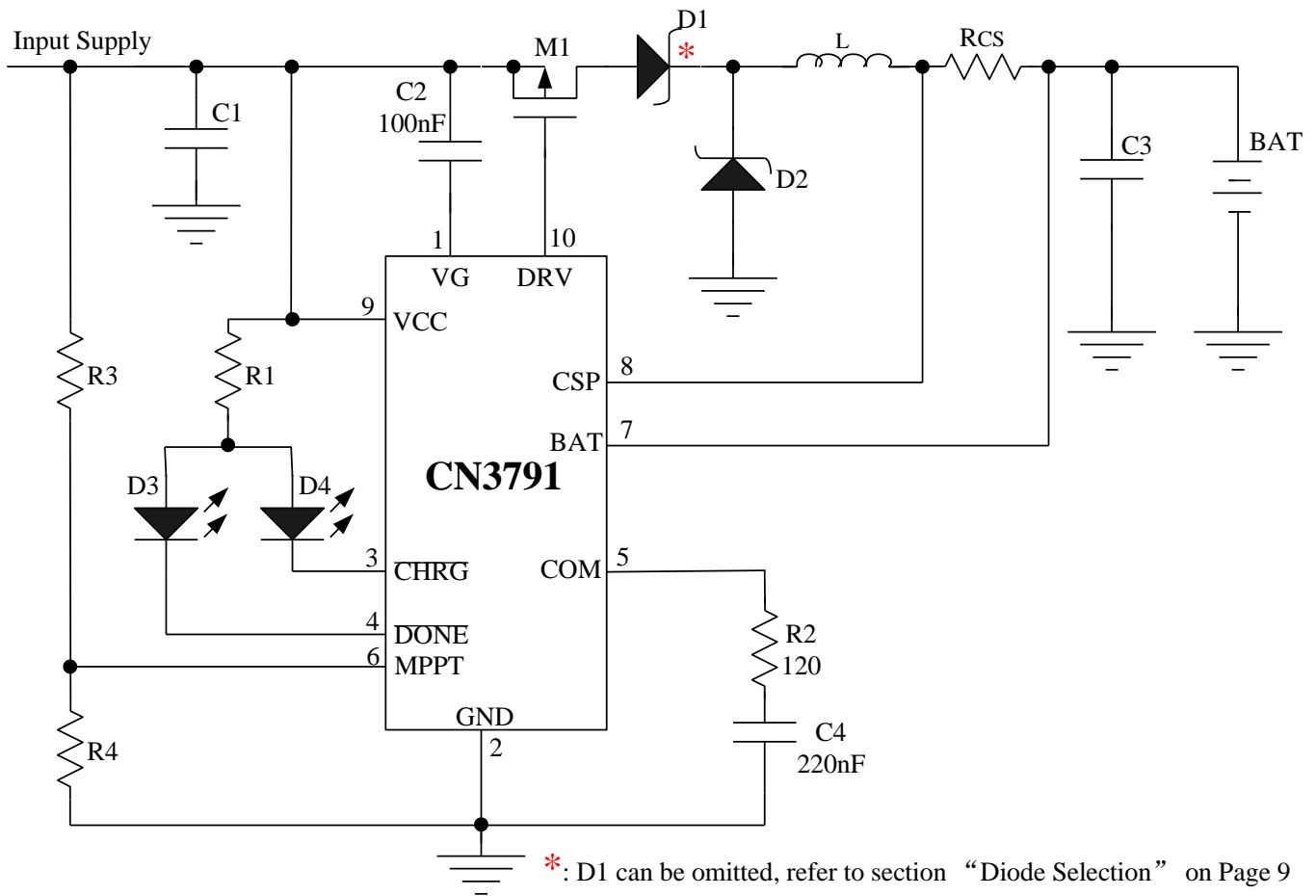

Figure 1 Typical Application Circuit

Ordering Information:

Part No.	Shipment	Operating Ambient Temperature
CN3791	Tape and Reel, 3000/Reel	-40°C to +85°C

CONSONANCE

Pin Description:

Pin No.	Name	Descriptions
1	VG	Internal Voltage Regulator. VG internally supplies power to gate driver, connect a 100nF capacitor between VG pin and VCC pin.
2	GND	Ground. Negative terminal of input supply.
3	$\overline{\text{CHRG}}$	Open-Drain Charge Status Output. When the battery is being charged, this pin is pulled low by an internal switch. Otherwise this pin is in high impedance state.
4	$\overline{\text{DONE}}$	Open-Drain Charge Termination Output. When the charging is terminated, this pin is pulled low by an internal switch. Otherwise this pin is in high impedance state.
5	COM	Loop Compensation Input. Connect a 220nF capacitor in series with an 120 Ω resistor from this pin to GND.
6	MPPT	Photovoltaic Cell Maximum Power Point Tracking Pin. Connect this pin to the external resistor divider for maximum power point tracking. In maximum power point tracking status, the MPPT pin's voltage is regulated to 1.205V.
7	BAT	Negative Input for Charge Current Sensing. This pin and the CSP pin measure the voltage drop across the sense resistor R_{CS} to provide the current signals required.
8	CSP	Positive Input for Charge Current Sensing. This pin and the BAT pin measure the voltage drop across the sense resistor R_{CS} to provide the current signals required.
9	VCC	External DC Power Supply Input. VCC is also the power supply for internal circuit. Bypass this pin with capacitors.
10	DRV	Gate Drive Pin. Drive the gate of external P-channel MOSFET.

Absolute Maximum Ratings

Voltage from VCC, VG, DRV, CHRG, DONE to GND.....	-0.3V to 30V
Voltage from VG to VCC.....	-8V to VCC+0.3V
Voltage from CSP, BAT, COM, MPPT to GND.....	-0.3V to 6.5V
Storage Temperature.....	-65°C to 150°C
Operating Ambient Temperature.....	-40°C to 85°C
Lead Temperature(Soldering, 10 seconds).....	260°C

Stresses beyond those listed under 'Absolute Maximum Ratings' may cause permanent damage to the device. These are stress ratings only and functional operation of the device at these or any other conditions above those indicated in the operational sections of the specifications is not implied. Exposure to Absolute Maximum Rating Conditions for extended periods may affect device reliability.

CONSONANCE

Electrical Characteristics:

(VCC=15V, T_A = -40°C to 85°C, unless otherwise noted)

Parameters	Symbol	Conditions	Min	Typ	Max	Unit
Input Voltage Range	VCC		4.5		28	V
Under voltage lockout Threshold	V _{UVLO}		3.1	3.8	4.4	V
Operating Current	I _{VCC}	No switching	0.7	1.0	1.3	mA
Regulation Voltage	V _{REG}	Constant voltage mode	4.158	4.2	4.247	V
Current Sense	V _{CS}	V _{BAT} > V _{PRE} , V _{CSP} - V _{BAT}	110	120	130	mV
		V _{BAT} < V _{PRE} , V _{CSP} - V _{BAT}	10	21	36	
Current into BAT Pin	I _{BAT1}	Termination, V _{BAT} = 3.7V		10	15	uA
	I _{BAT2}	Sleep mode, V _{BAT} = 3.7V			15	
Precharge Threshold	V _{PRE}	V _{BAT} rises	64	66.5	69	% V _{REG}
Precharge Threshold Hysteresis	H _{PRE}	V _{BAT} falls		2.5		% V _{REG}
Charge Termination Threshold	I _{term}	Charge current decreases		16		% I _{CC}
Recharge Threshold	V _{RE}	V _{BAT} falls		95.5		% V _{REG}
Overvoltage Trip Level	V _{OV}	V _{BAT} rises	1.04	1.07	1.1	V _{REG}
Overvoltage Clear Level	V _{clr}	V _{BAT} falls	1.0	1.02	1.04	
MPPT Pin						
MPPT Regulation Voltage	V _{MPPT}	Maximum power point track	1.18	1.205	1.23	V
MPPT Pin Bias Current	I _{MPPT}		-100	0	+100	nA
CHRG Pin						
CHRG Pin Sink Current	I _{CHRG}	V _{CHRG} = 1V, charge mode	7	12	18	mA
CHRG Leakage Current	I _{LK1}	V _{CHRG} = 25V, termination mode			1	uA
DONE Pin						
DONE Sink Current	I _{DONE}	V _{DONE} = 1V, termination mode	7	12	18	mA
DONE Leakage Current	I _{LK2}	V _{DONE} = 25V, charge mode			1	uA
Oscillator						
Switching Frequency	f _{osc}		240	300	360	kHZ
Maximum Duty Cycle	D _{max}			94		%
Sleep Mode						
Sleep Mode Threshold	V _{SLP}	VCC falling, V _{BAT} = 3.7V, measure VCC - V _{BAT}	0.0	0.02	0.1	V
Sleep mode Release Threshold	V _{SLPR}	VCC rising, V _{BAT} = 3.7V, measure VCC - V _{BAT}	0.26	0.32	0.39	V

Note: V_{REG} is the regulated voltage in constant voltage mode; I_{CC} is the charge current in constant current mode.

CONSONANCE

Electrical Characteristics: (Continued)

Parameters	Symbol	Conditions	Min	Typ	Max	Unit
DRV Pin						
V _{DRV} High (VCC - V _{DRV})	VH	I _{DRV} = -10mA		60		mV
V _{DRV} Low (VCC - V _{DRV})	VL	I _{DRV} = 0mA		6.3		V
Rise Time	t _r	Load = 2nF, 10% to 90%	30	40	65	Ns
Fall Time	t _f	Load = 2nF, 90% to 10%	30	40	65	Ns

Detailed Description:

The CN3791 is a constant current, constant voltage Li-Ion battery charger controller that can be powered by the photovoltaic cell with maximum power point tracking function, the device adopts PWM step-down (buck) switching architecture. The charge current is set by an external sense resistor (R_{CS}) across the CSP and BAT pins. The final battery regulation voltage in constant voltage mode is set at 4.2V typical with 1% accuracy.

A charge cycle begins when the voltage at the VCC pin rises above V_{UVLO} and the battery voltage by V_{SLPR}, and the voltage at MPPT pin is greater than 1.23V. At the beginning of the charge cycle, if the battery voltage is less than 66.5% of regulation voltage (V_{REG}), the charger goes into trickle charge mode. The trickle charge current is internally set to 17.5% (Typical) of the full-scale current. When the battery voltage exceeds 66.5% of regulation voltage, the charger goes into the full-scale constant current charge mode. In constant current mode, the charge current is set by the external sense resistor R_{CS} and an internal 120mV reference, the charge current equals to 120mV/R_{CS}. When the battery voltage approaches the regulation voltage, the charger goes into constant voltage mode, and the charge current will start to decrease. When the charge current drops to 16% of the full-scale current, the charge cycle is terminated, the DRV pin is pulled up to VCC, and an internal comparator turns off the internal pull-down N-channel MOSFET at the $\overline{\text{CHRG}}$ pin, another internal pull-down N-channel MOSFET at the $\overline{\text{DONE}}$ pin is turned on to indicate the termination status.

To restart the charge cycle, just remove and reapply the input voltage. Also, a new charge cycle will begin if the battery voltage drops below the recharge threshold voltage of 95.5% of the regulation voltage.

The CN3791 adopts the constant voltage method to track the photovoltaic cell's maximum power point. The MPPT pin's voltage is regulated to 1.205V to track the maximum power point of the solar panel.

When the input voltage is not present, the charger automatically goes into sleep mode, all the internal circuits are shutdown.

An overvoltage comparator guards against voltage transient overshoots (>7% of regulation voltage). In this case, P-channel MOSFET are turned off until the overvoltage condition is cleared. This feature is useful for battery load dump or sudden removal of battery.

The charging profile is shown in Figure 2.

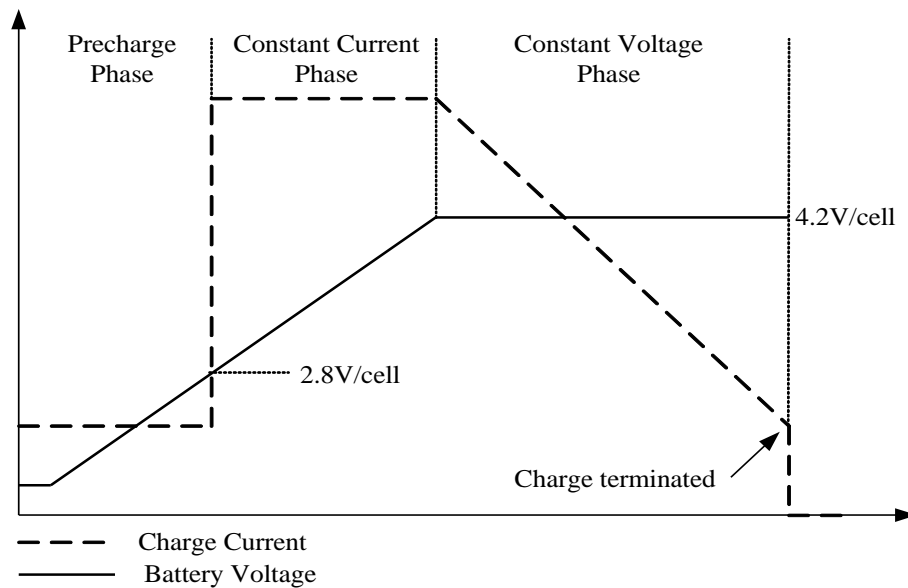

Figure 2 The Charging Profile(FB pin is connected to BAT pin)

Application Information

Under voltage Lockout (UVLO)

An under voltage lockout circuit monitors the input voltage and keeps the charger off if VCC falls below 3.8V(Typical).

Trickle Charge Mode

At the beginning of a charge cycle, if the battery voltage is below 66.5% of the regulation voltage, the charger goes into trickle charge mode with the charge current reduced to 17.5% of the full-scale current.

Charge Current Setting

The full-scale charge current, namely the charge current in constant current mode, is decided by the following formula:

$$I_{CH} = \frac{120mV}{R_{CS}}$$

Where:

I_{CH} is the full scale charge current

R_{CS} is the resistor between the CSP pin and BAT pin

The Maximum Power Point Tracking

CN3791 adopts the constant voltage method to track the photovoltaic cell's maximum power point. From I-V curve of photovoltaic cell, under a given temperature, the photovoltaic cell's voltages at the maximum power point are nearly constant regardless of the different irradiances. So the maximum power point can be tracked if the photovoltaic cell's output voltage is regulated to a constant voltage.

CN3791's MPPT pin's voltage is regulated to 1.205V to track the maximum power point working with the off-chip resistor divider(R3 and R4 in Figure 1).

The maximum power point voltage is decided by the following equation:

$$V_{MPPT} = 1.205 \times (1 + R3 / R4)$$

Charge Termination

In constant voltage mode, the charge current decreases gradually. When the charge current decreases to 16% of the full-scale current, the charging is terminated, the external P-channel MOSFET is turned off, no charge

CONSONANCE

current is delivered to battery any more.

Automatic Recharge

After the charge cycle is completed and both the battery and the input power supply (wall adapter) are still present, a new charge cycle will begin if the battery voltage drops below 95.5% of the regulation voltage due to self-discharge or external loading. This will keep the battery capacity at more than 80% at all times without manually restarting the charge cycle.

Status Indication

The CN3791 has 2 open-drain status outputs: $\overline{\text{CHRG}}$ and $\overline{\text{DONE}}$. $\overline{\text{CHRG}}$ pin is pulled low when the charger is in charging status, otherwise $\overline{\text{CHRG}}$ becomes high impedance. $\overline{\text{DONE}}$ pin is pulled low if the charger is in charge termination status, otherwise $\overline{\text{DONE}}$ becomes high impedance.

When the battery is not present, the charger charges the output capacitor to the regulation voltage quickly, then the BAT pin's voltage decays slowly to recharge threshold because of low leakage current at BAT pin, which results in a ripple waveform at BAT pin, in the meantime, $\overline{\text{CHRG}}$ pin outputs pulse to indicate the battery's absence.

The open drain status output that is not used should be tied to ground.

The table 1 lists the two indicator status and its corresponding charging status. It is supposed that red LED is connected to $\overline{\text{CHRG}}$ pin and green LED is connected to $\overline{\text{DONE}}$ pin.

$\overline{\text{CHRG}}$ pin	$\overline{\text{DONE}}$ pin	State Description
Low(the red LED on)	High Impedance(the green LED off)	Charging
High Impedance(the red LED off)	Low(the green LED on)	Charge termination
Pulse (the red LED blinking)	Pulse (the green LED on or blinking)	Battery not present
High Impedance(the red LED off)	High Impedance(the green LED off)	There are 2 possible reasons: <ul style="list-style-type: none">● the voltage at the VCC pin below the UVLO level or● the voltage at the VCC pin below V_{BAT}

Table 1 Indication Status

Gate Drive

The CN3791's gate driver can provide high transient currents to drive the external pass transistor. The rise and fall times are typically 40ns when driving a 2000pF load, which is typical for a P-channel MOSFET with $R_{\text{ds(on)}}$ in the range of 30m Ω .

A voltage clamp is added to limit the gate drive to 8V max. below VCC. For example, if VCC is 20V, then the DRV pin output will be pulled down to 12V min. This allows low voltage P-channel MOSFETs with superior $R_{\text{ds(on)}}$ to be used as the pass transistor thus increasing efficiency.

Loop Compensation

In order to make sure that the current loop and the voltage loop are stable, a series-connected 220nF ceramic capacitor and 120 Ω resistor from the COM pin to GND are necessary.

Battery Detection

CN3791 does not provide battery detection function, when the battery is not present, the charger charges the output capacitor to the regulation voltage quickly, then the BAT pin's voltage decays slowly to recharge threshold because of low leakage current at BAT pin, which results in a ripple waveform at BAT pin, in the meantime, $\overline{\text{CHRG}}$ pin outputs pulse to indicate the battery's absence.

It is generally not a good practice to connect a battery while the charger is running, otherwise the charger may be

CONSONANCE

in uncertain state, or deliver a large surge current into the battery for a brief time.

Input Capacitors

Since the input capacitor (C1 in Figure 1) is assumed to absorb all input switching ripple current in the converter, it must have an adequate ripple current rating. Worst-case RMS ripple current is approximately one-half of output charge current.

In order to depress the high-frequency oscillation during P-channel MOSFET's turning on and off, it is best that the input capacitor consists of the following 3 capacitors in parallel:

- Electrolytic capacitor for low-frequency filtering
- A ceramic capacitor from 1uF to 10uF
- A high-frequency capacitor from 47nF to 1uF

Output Capacitors

The selection of output capacitor (C3 in Figure 1) is primarily determined by the ESR required to minimize ripple voltage and load step transients. It is best that the output capacitor consists of the following 2 capacitors in parallel:

- A 10uF electrolytic capacitor for low-frequency filtering
- A ceramic capacitor from 1uF to 10uF

If only ceramic capacitor can be used, care must be taken that some ceramic capacitors exhibit large voltage coefficient, which may lead to high voltage at BAT pin when battery is not present. In this case, the capacitor value should be increased properly so that no damage will be done.

Inductor Selection

During P-channel MOSFET's on time, the inductor current increases, and decreases during P-channel MOSFET's off time, the inductor's ripple current increases with lower inductance and higher input voltage. Higher inductor ripple current results in higher charge current ripple and greater core losses. So the inductor's ripple current should be limited within a reasonable range.

The inductor's ripple current is given by the following formula:

$$\Delta I_L = \frac{1}{f(L)} V_{BAT} \left(1 - \frac{V_{BAT}}{V_{CC}}\right)$$

Where,

f is the switching frequency 300KHz

L is the inductor value

V_{BAT} is the battery voltage

V_{CC} is the input voltage

A reasonable starting point for setting inductor ripple current is $\Delta I_L = 0.3 \times I_{CH}$, I_{CH} is the charge current. Remember that the maximum ΔI_L occurs at the maximum input voltage and the lowest inductor value. So lower charge current generally calls for larger inductor value.

In the meantime, inductor value should meet the requirement of the following equation:

$$L > 5 \times (V_{CC} - V_{BAT}) \quad (\mu H)$$

MOSFET Selection

The CN3791 uses a P-channel power MOSFET switch. The MOSFET must be selected to meet the efficiency or power dissipation requirements of the charging circuit as well as the maximum temperature of the MOSFET. The peak-to-peak gate drive voltage is set internally, this voltage is typically 6.3V. Consequently, logic-level threshold MOSFETs must be used. Pay close attention to the BV_{DSS} specification for the MOSFET as well; many of the logic-level MOSFETs are limited to 30V or less.

Selection criteria for the power MOSFET includes the "on" resistance R_{ds(on)}, total gate charge Q_g, reverse

CONSONANCE

transfer capacitance C_{RSS} , input voltage and maximum current.

The MOSFET power dissipation at maximum output current is approximated by the equation:

$$P_d = \frac{V_{BAT}}{V_{CC}} \times R_{ds(on)} \times I_{CH}^2 \times (1 + 0.005 dT)$$

Where:

P_d is the power dissipation of the power MOSFET

V_{BAT} is the maximum battery voltage

V_{CC} is the minimum input voltage

$R_{ds(on)}$ is the power MOSFET's on resistance at room temperature

I_{CH} is the charge current

dT is the temperature difference between actual ambient temperature and room temperature(25°C)

In addition to the $I^2R_{ds(on)}$ loss, the power MOSFET still has transition loss, which are highest at the highest input voltage. Generally speaking, for $V_{IN} < 20V$, the $I^2R_{ds(on)}$ loss may be dominant, so the MOSFET with lower $R_{ds(on)}$ should be selected for better efficiency; for $V_{IN} > 20V$, the transition loss may be dominant, so the MOSFET with lower C_{RSS} can provide better efficiency. C_{RSS} is usually specified in the MOSFET characteristics; if not, then C_{RSS} can be calculated using $C_{RSS} = Q_{GD}/\Delta V_{DS}$.

The MOSFETs such as CN2305, 4459, 4435, 9435, 3407A can be used. The part numbers listed above are for reference only, the users can select the right MOSFET based on their requirements.

Diode Selection

The diodes D1 and D2 in Figure 1 are schottky diode, the current rating of the diodes should be at least the charge current limit, the voltage rating of the diode should exceed the maximum expected input voltage.

The diode that is much larger than that is sufficient can result in larger transition losses due to their larger junction capacitance.

Diode D1 in Figure 1 is used as block diode to prevent battery current from flowing back to V_{CC} when input supply is absent. Even without D1, CN3791 consumes only about 30uA current from battery($V_{BAT}=4.2V$), so diode D1 can be removed if the 30uA battery current is not a consideration.

Battery Current In Sleep Mode

In the typical application circuit shown in Figure 1, when input voltage is powered off or lower than battery voltage, CN3791 will enter sleep mode. In sleep mode, the battery current includes:

- (1) The current into BAT pin and CSP pin, which is about 9uA($V_{BAT}=4.2V$).
- (2) The current from battery to V_{CC} pin via diode D1, which is determined by D1's leakage current. If diode D1 is not used, then the current flowing to V_{CC} pin via inductor and body diode of P-channel MOSFET is about 21uA($V_{BAT}=4.2V$).
- (3) The current from battery to GND via diode D2, which is also determined by D2's leakage current.

PCB Layout Considerations

When laying out the printed circuit board, the following considerations should be taken to ensure proper operation of the IC.

- (1) To minimize radiation, the 2 diodes, pass transistor, inductor and the input bypass capacitor traces should be kept as short as possible. The positive side of the input capacitor should be close to the source of the P-channel MOSFET; it provides the AC current to the pass transistor. The connection between the diode and the pass transistor should also be kept as short as possible.
- (2) The compensation capacitor connected at the COM pin should return to the ground pin of the IC. This will prevent ground noise from disrupting the loop stability.
- (3) Output capacitor ground and catch diode (D2 in Figure 1) ground connections need to feed into same copper that connects to the input capacitor ground before tying back into system ground.

CONSONANCE

- (4) Analog ground and power ground(or switching ground) should return to system ground separately.
- (5) The ground pins also works as a heat sink, therefore use a generous amount of copper around the ground pins. This is especially important for high VCC and/or high gate capacitance applications.
- (6) Place the charge current sense resistor R_{CS} right next to the inductor output but oriented such that the IC's CSP and BAT traces going to R_{CS} are not long. The 2 traces need to be routed together as a single pair on the same layer at any given time with smallest trace spacing possible.
- (7) The CSP and BAT pins should be connected directly to the 2 terminals of current sense resistor (Kelvin sensing) for best charge current accuracy. See Figure 3 as an example.

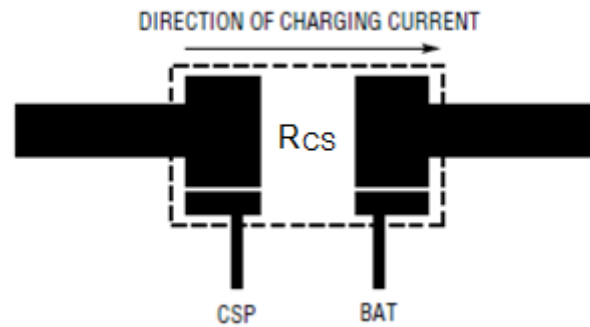
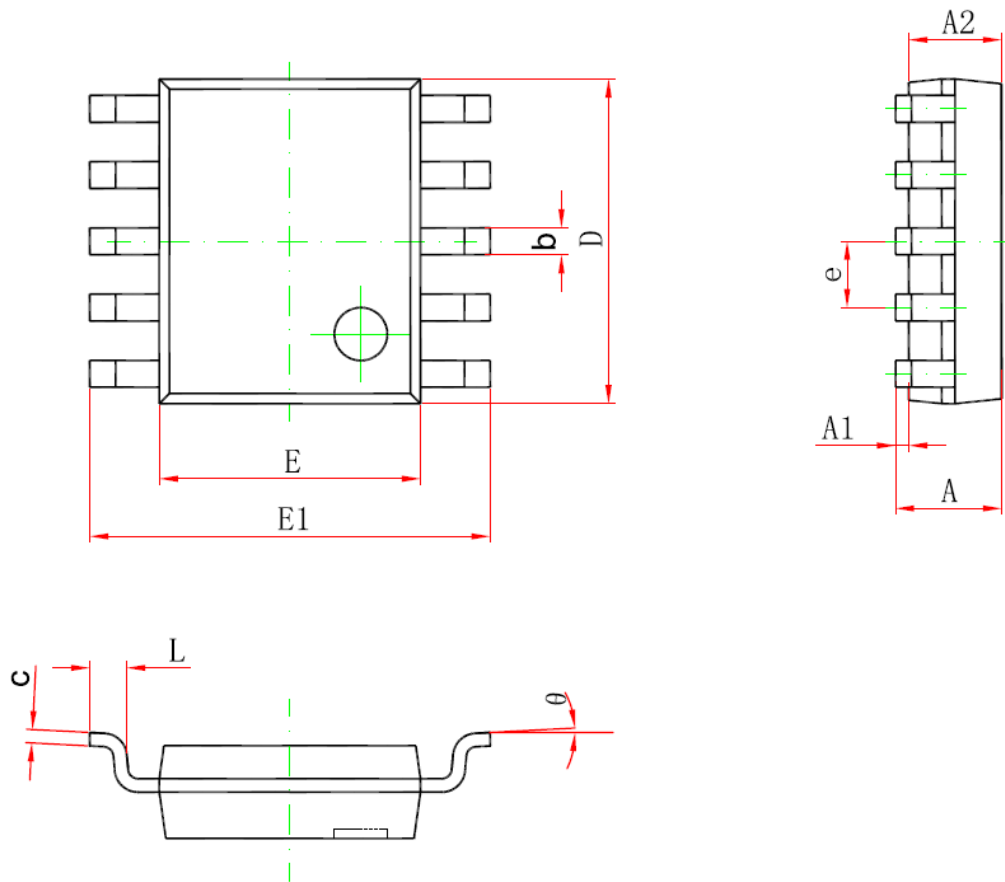

Figure 3 Kelvin Sensing of Charge Current

CONSONANCE

Package Information



Symbol	Dimensions In Millimeters		Dimensions In Inches	
	Min	Max	Min	Max
A	1.350	1.750	0.053	0.069
A1	0.100	0.250	0.004	0.010
A2	1.350	1.550	0.053	0.061
b	0.300	0.450	0.012	0.018
c	0.170	0.250	0.007	0.010
D	4.700	5.100	0.185	0.201
E	3.800	4.000	0.150	0.157
E1	5.800	6.200	0.228	0.244
e	1.000 (BSC)		0.039 (BSC)	
L	0.400	1.270	0.016	0.050
θ	0°	8°	1°	8°

Consonance does not assume any responsibility for use of any circuitry described. Consonance reserves the right to change the circuitry and specifications without notice at any time.